

Study of pure CsI crystal coupling with APD

University of Tokyo

Yi-Fan JIN

BELLE II @ SuperKEKB

High Energy Physics Experiment

Electron-positron collider

Studies CP violation

Using B mesons

High luminosity/power output

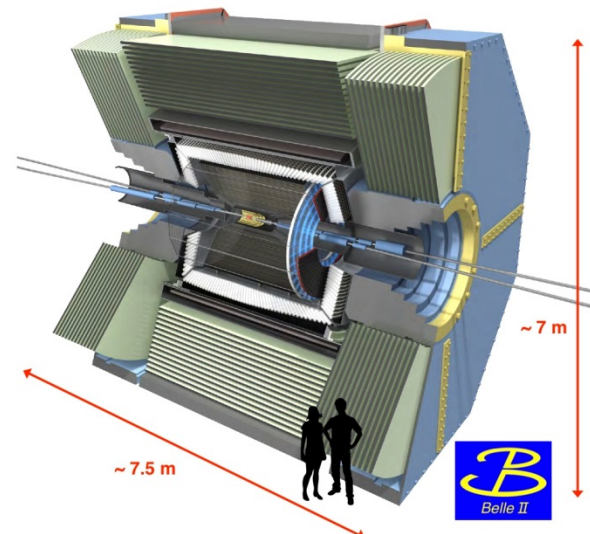
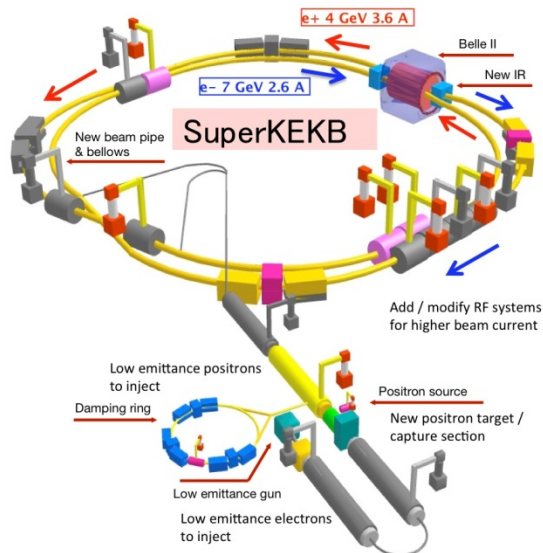

Electromagnetic Calorimeter (ECL) Upgrade

New electronics design (waveform analysis)

Reduce radiation damage

Handle x40 background

Candidates:

photopentode VS Avalanche photodiode (APD)

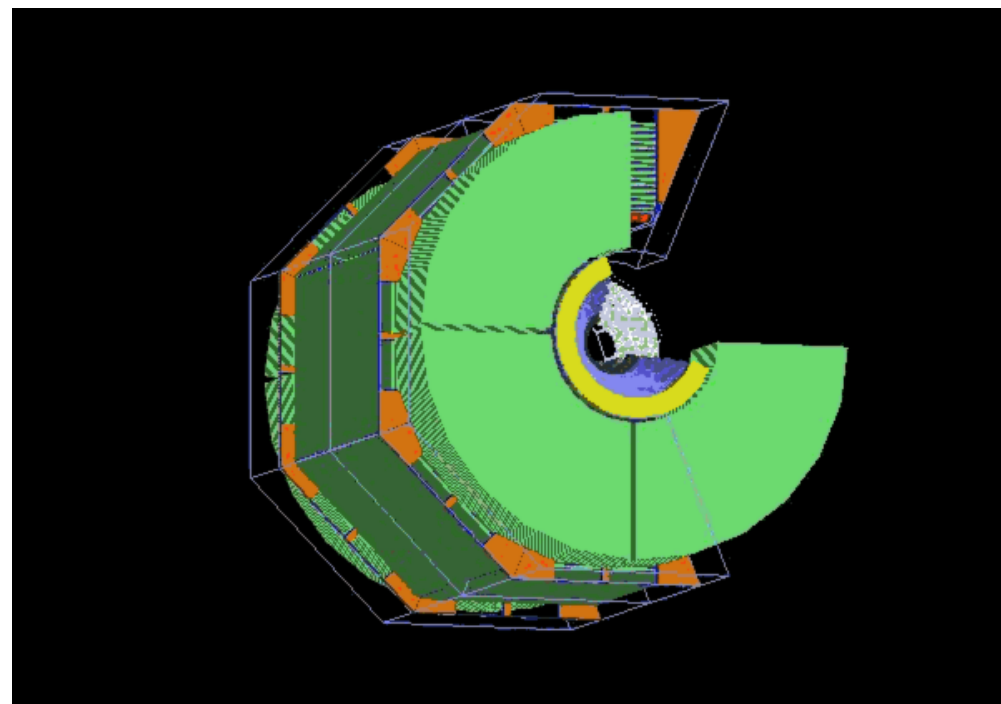
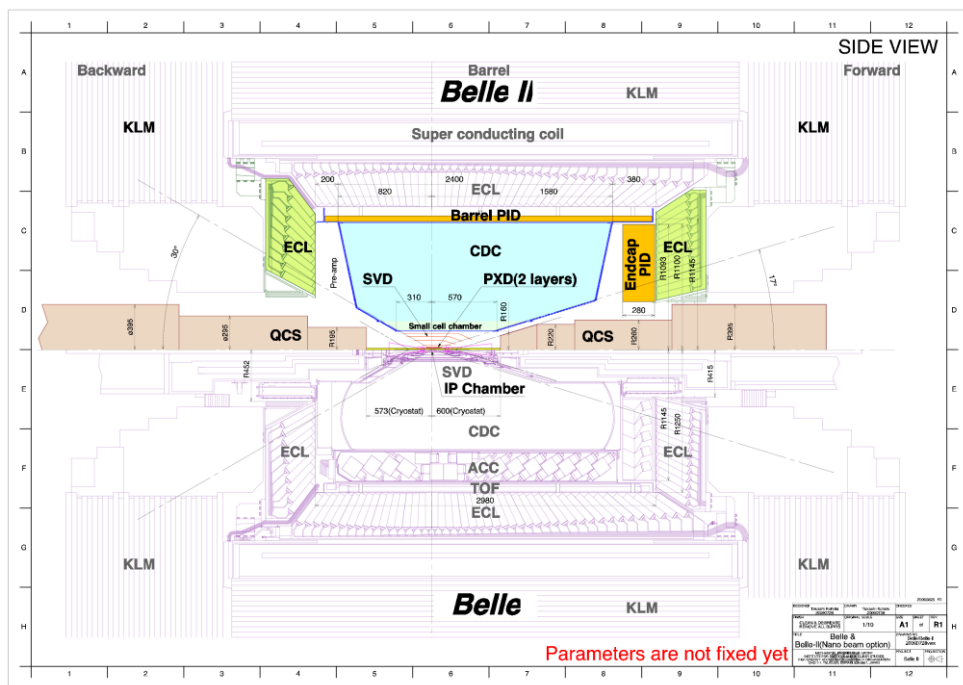

Pure Cesium Iodide (CsI) scintillation crystal

Cesium Iodide is a material with high γ -ray stopping power due to its relative high density and atomic number. Undoped CsI, being an intrinsic scintillator, has very different scintillation properties from the more widely used CsI(Tl) or CsI(Na) activated by Tl or Na respectively.

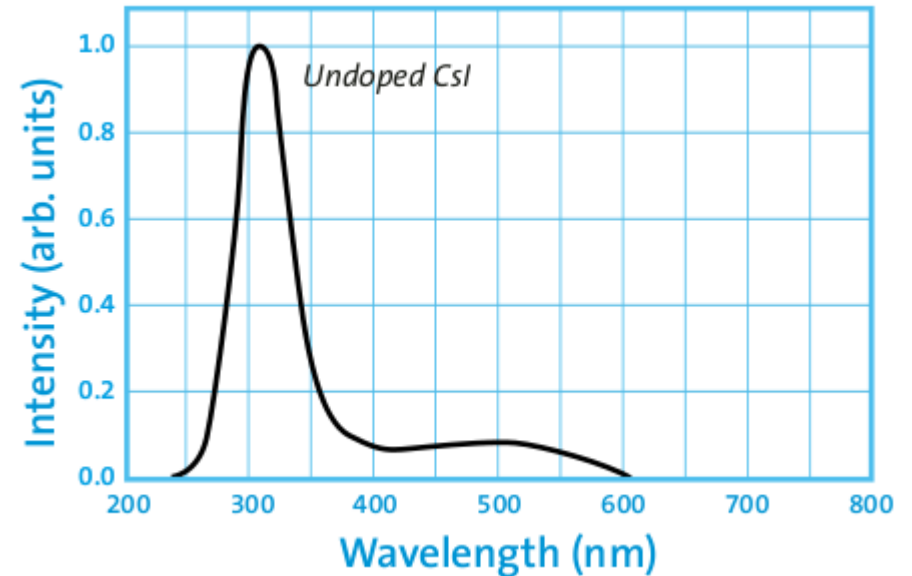

Silicon Avalanche Photodiode (APD)

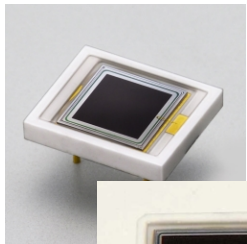

Hamamatsu APD

S8664-55

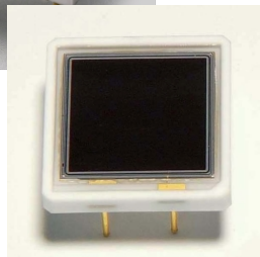

S8664-1010

Features:

- High sensitivity at visible range
- Low noise
- High gain
- Low capacitance

TASK: noise~0.5 MeV

Study of ENC

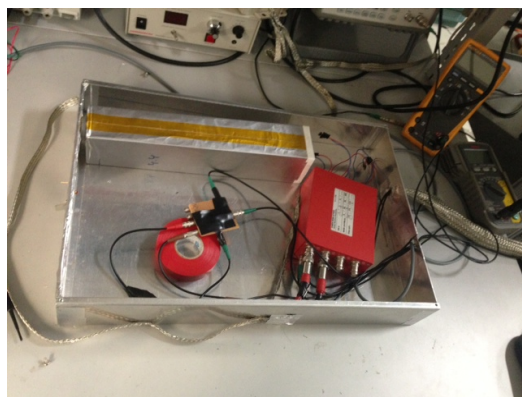
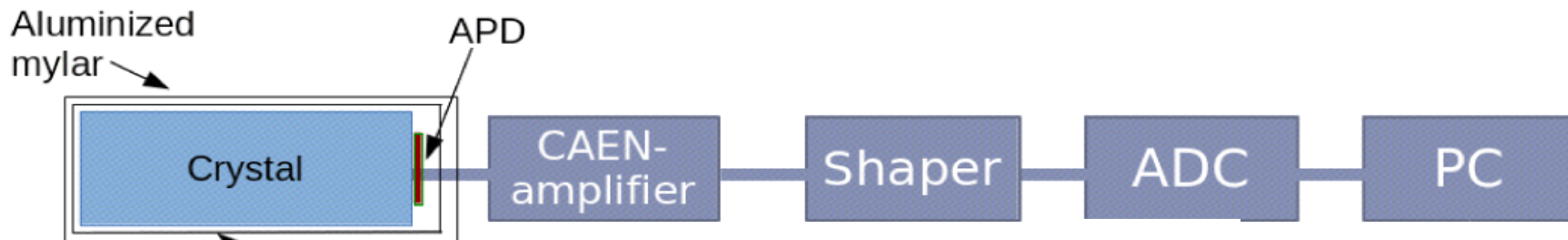

**4ch preamplifier
CAEN A1422B045F3
45 mV/MeV (1 V/pC)**

**CP 4467A
Fast Shaping
Amplifier (NIM)
 $\tau=20-500$ ns**



**Hoshin C008
16ch peak hold
ADC (CAMAC)**

$$ENC^2 = \frac{2I_d K g F \tau}{e} + \left(\frac{B^2}{\tau} + E^2 \right) C^2 + D^2$$

Shot noise
Thermal noise
Additional noise

- e** – electron charge;
- I_d** – dark current;
- g** – APD gain;
- τ** – shaping time;
- K** – shaper factor;
- F** – excess noise factor;
- C** – APD capacitance;
- B** – thermal noise coefficient;
- D** – additional noise.

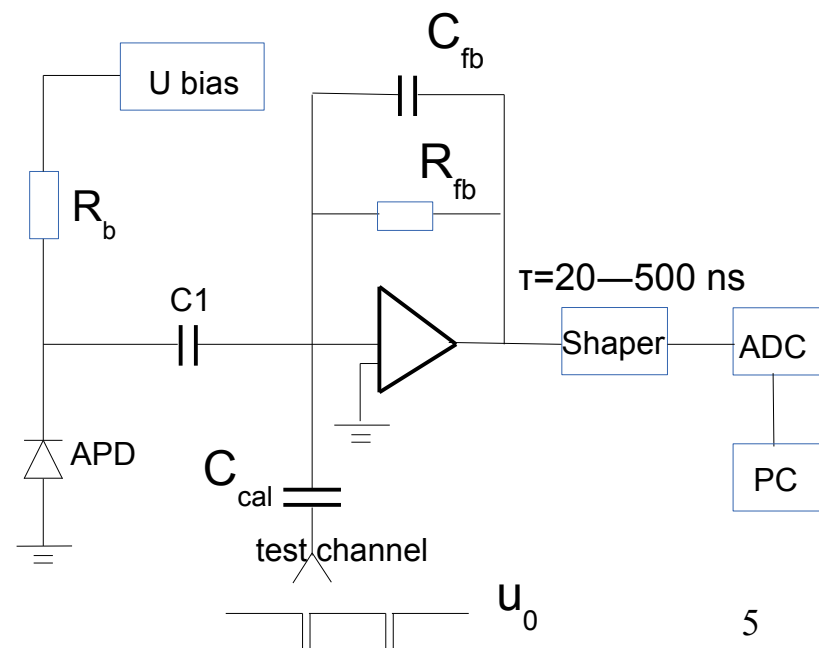

Measurement of **D**

Measurement

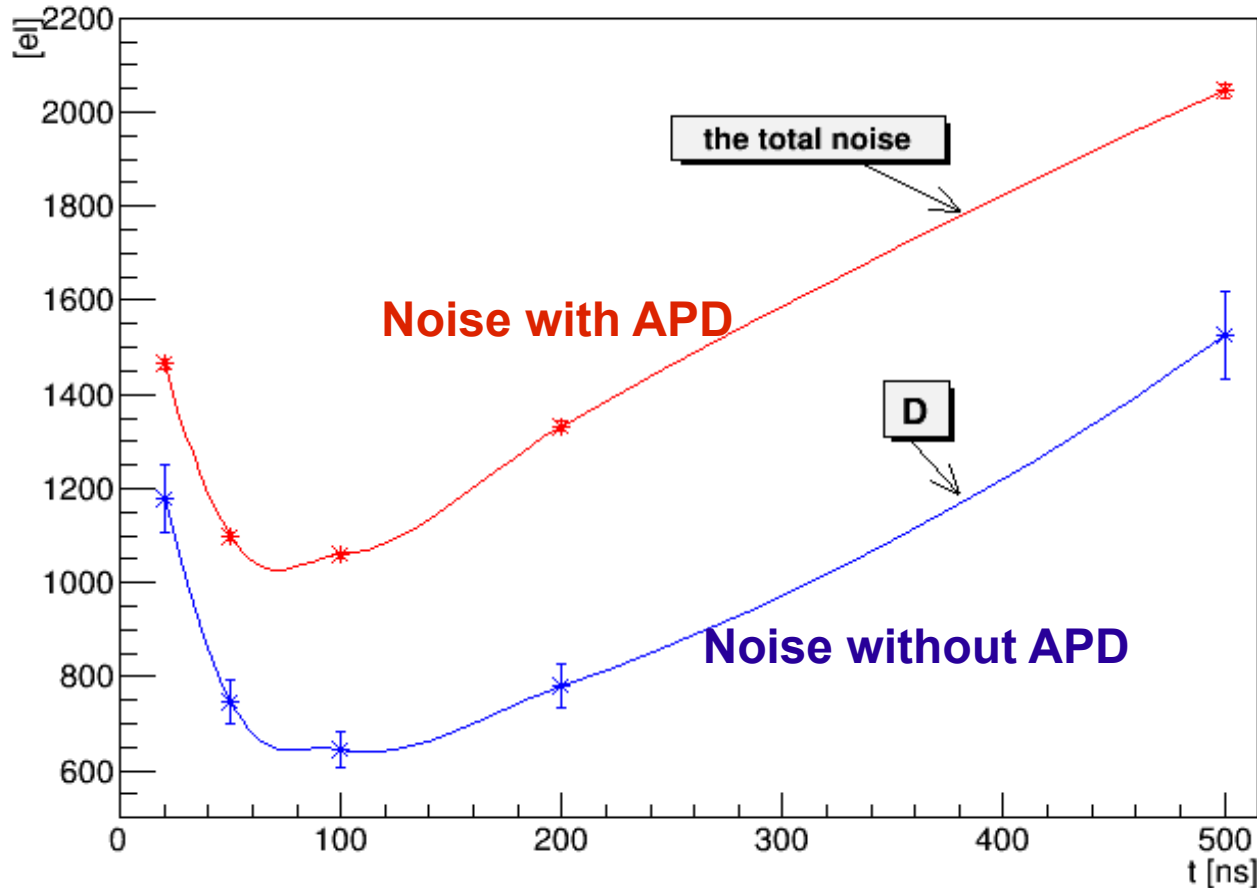

- At the shaping times from 20 ns to 500 ns, **D** is not constant. It varies strongly, which is explained by the relatively large additional parallel (i_{na}) and serial (e_{na}) noises.
- Fast shaper of better quality (like ORTEC 474, 579) might be helpful to decrease **D**

$$ENC^2 = (2eI_d + \frac{4k_bT}{R_b} + i_{na}^2)K_iT_s + (4k_bTR_s + e_{na}^2)K_v\frac{C^2}{T_s} + K_{\nu f}A_fC^2$$

$$ENC^2 = \frac{2I_dKgF\tau}{e} + (\frac{B^2}{\tau} + E^2)C^2 + D^2$$

Measurement of thermal noise (**B**, **E**)

Two well known capacitors C_1 and C_2 were used to measure **B** and **E**.

$$\mathbf{B}^2/\mathbf{T} + \mathbf{E} = (\overline{Q_1^2} - \overline{Q_2^2}) / (C_1^2 - C_2^2)$$

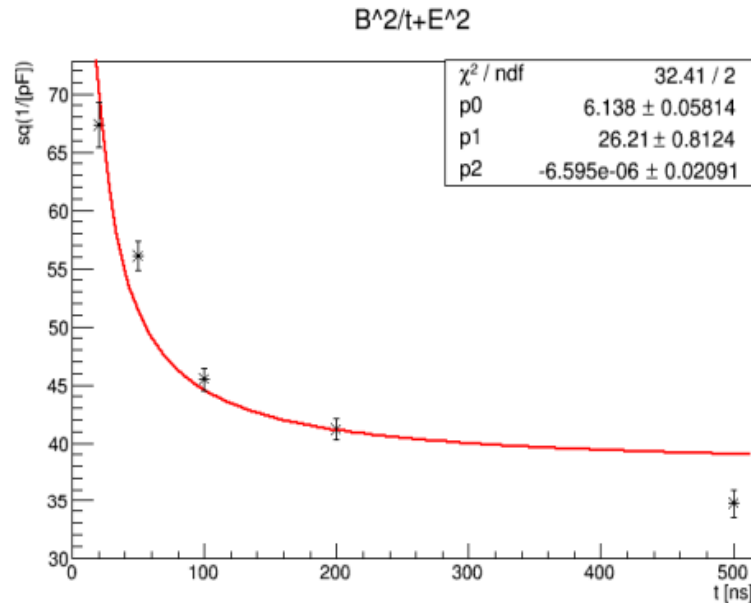

(a) without systematic error

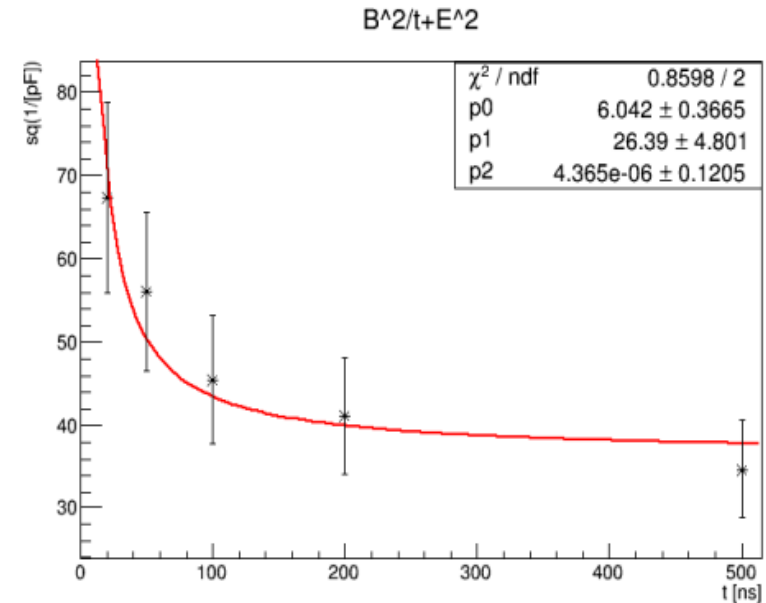

(b) with systematic error

$$\mathbf{B} = 26.2 \pm 0.8 \pm 4.8 \sqrt{\text{ns/pF}},$$

$$\mathbf{E} = 6.1 \pm 0.1 \pm 0.4 \text{ 1/pF}$$

$$\mathbf{B}^2/\mathbf{T} = (4k_B \mathbf{T} R_S \Delta f) / e^2$$

$R_S = 50 \Omega$ was measured with additional serial resistance at the preamplifier input

Shot noise, excess noise factor F

$$\overline{Q^2}_{\text{no } I_{\text{photo}}} = 2 \cdot e \cdot I_d \cdot T \cdot g \cdot F \cdot K + (B^2/T + E) \cdot C_d^2 + D^2$$

$$\overline{Q^2}_{\text{with } I_{\text{photo}}} = 2 \cdot e \cdot (I_d + I_{\text{photo}}) \cdot T \cdot g \cdot F \cdot K + (B^2/T + E) \cdot C_d^2 + D^2$$

$$\text{So, } F = (\overline{Q^2}_{\text{with } I_{\text{photo}}} - \overline{Q^2}_{\text{no } I_{\text{photo}}}) / (2 \cdot e \cdot I_{\text{photo}} \cdot T \cdot g \cdot K)$$

$$K(\text{EXP}) = 0.44 \pm 0.02 \quad K(\text{CR-4RC}) = 0.45$$

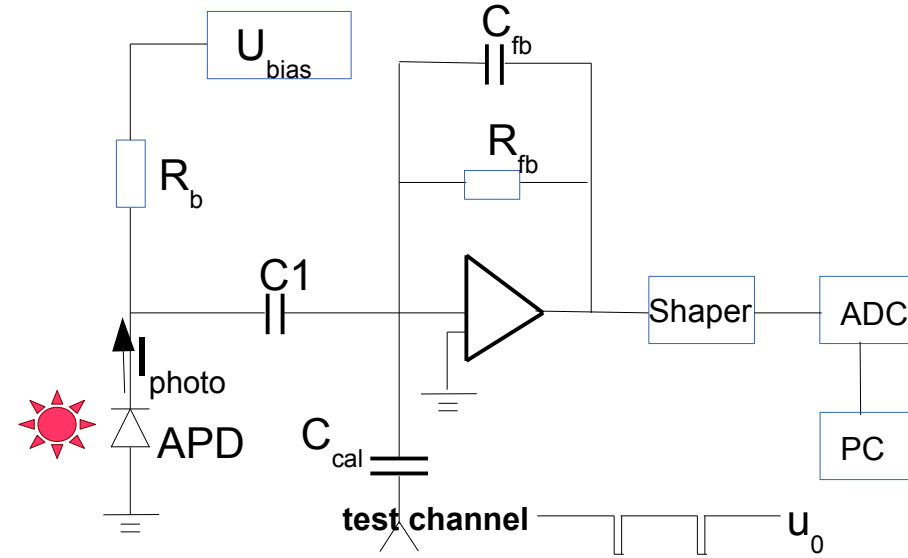

Measurement of F on S8664-55

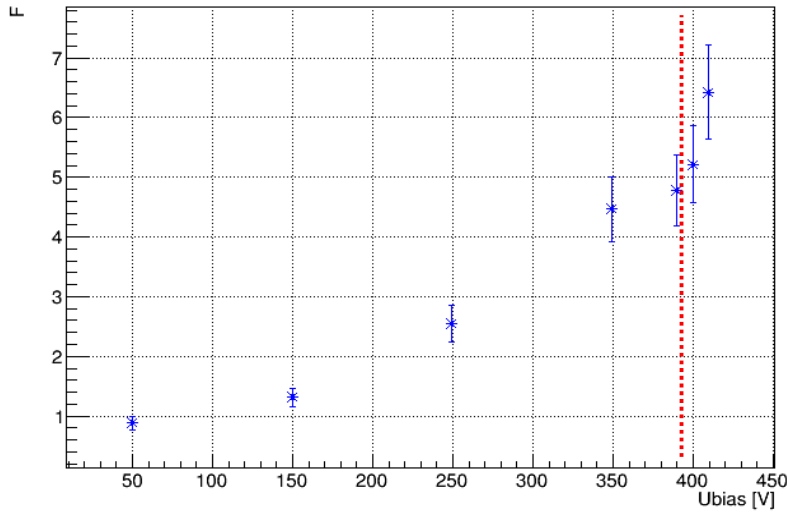

S8664-55: $g = 50$, $F = 5.1 \pm 0.5$

Measurement of F on S8664-1010

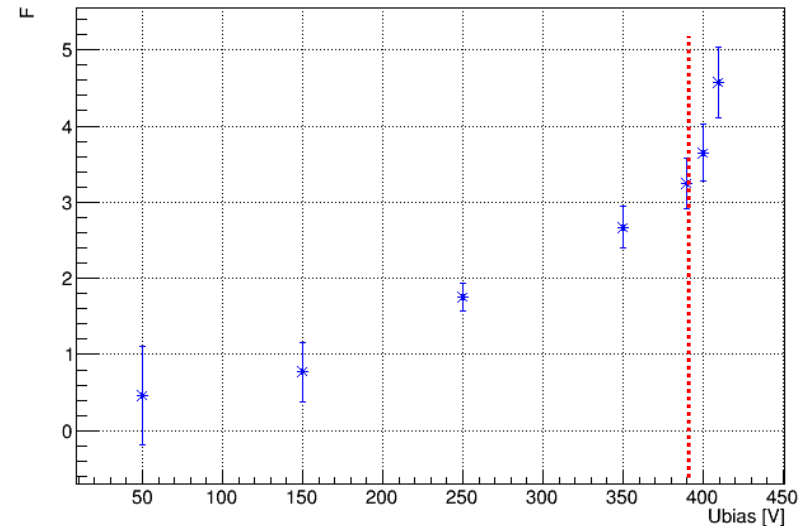

S8664-1010: $g = 50$, $F = 3.4 \pm 0.4$

ENC vs. T

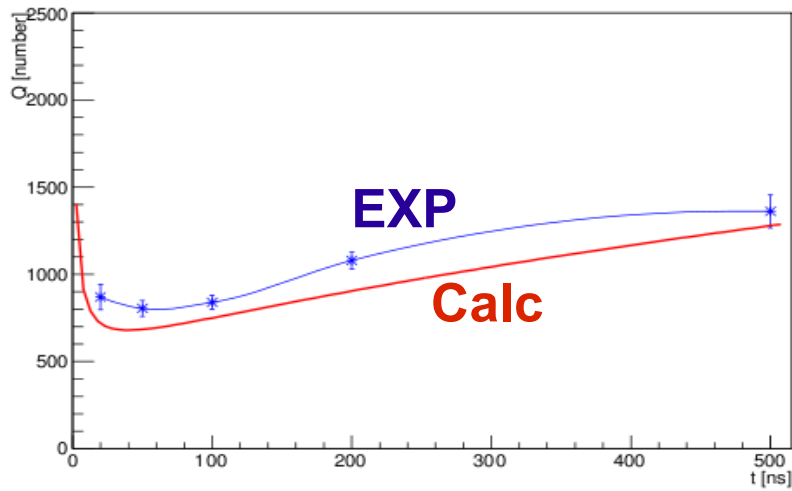
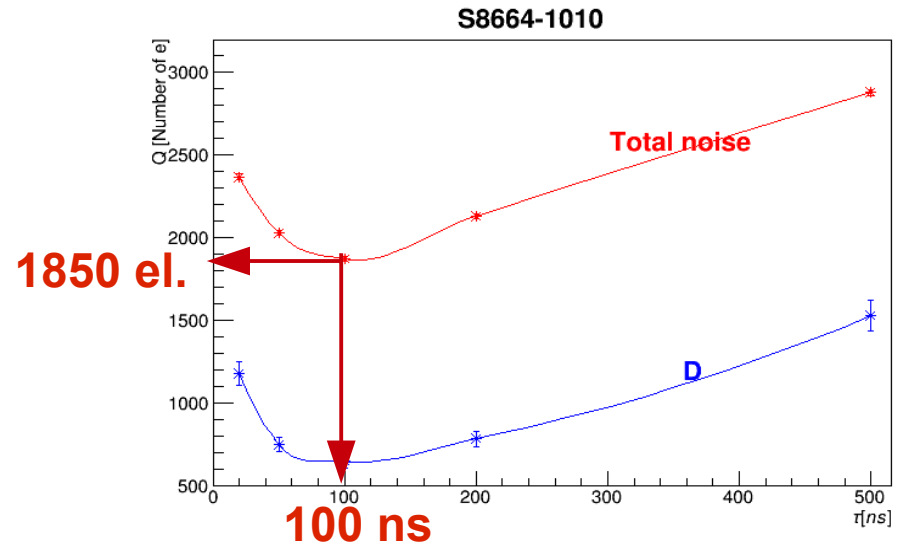
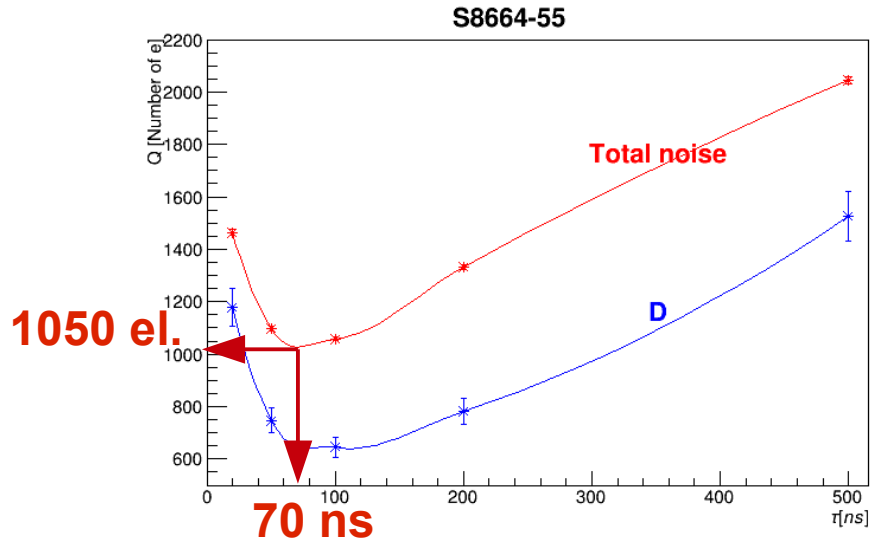

(a) S8664-55

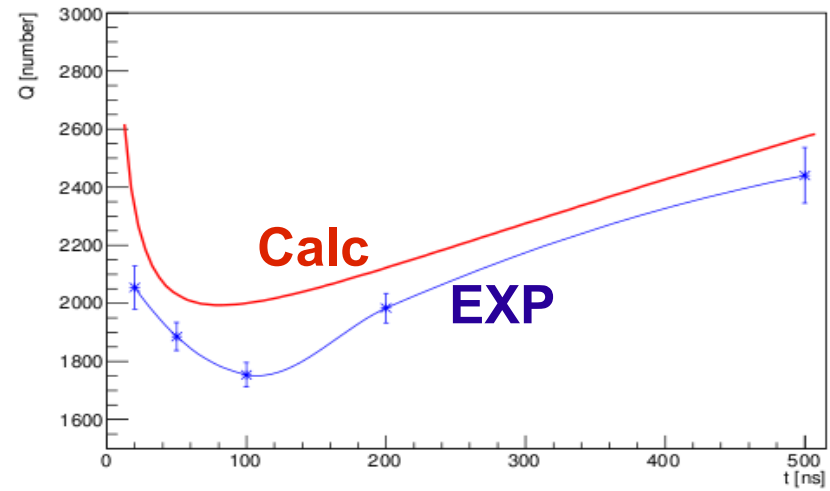

(b) S8664-1010

Discrepancy between **EXP** and **Calc** is due to the uncertainty in C_{APD}

Light output (LO) and ENE

Cosmic muons are used to calibrate ADC channels in units of energy (MeV)

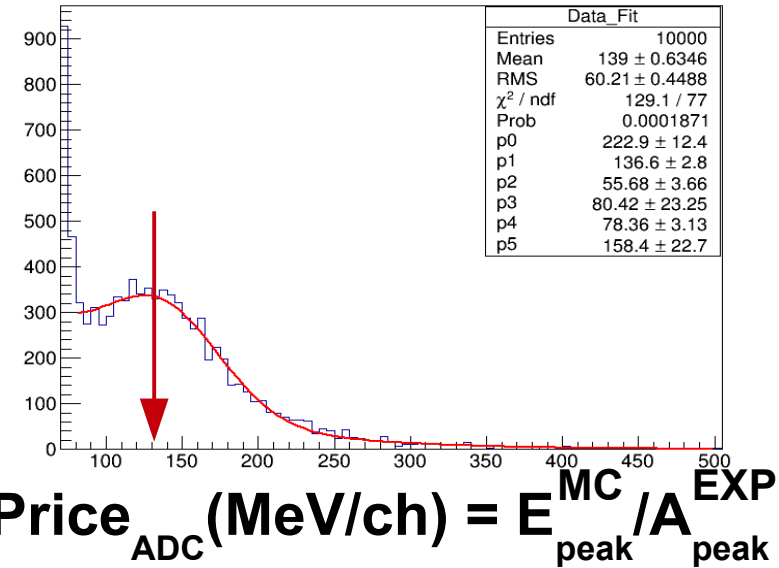
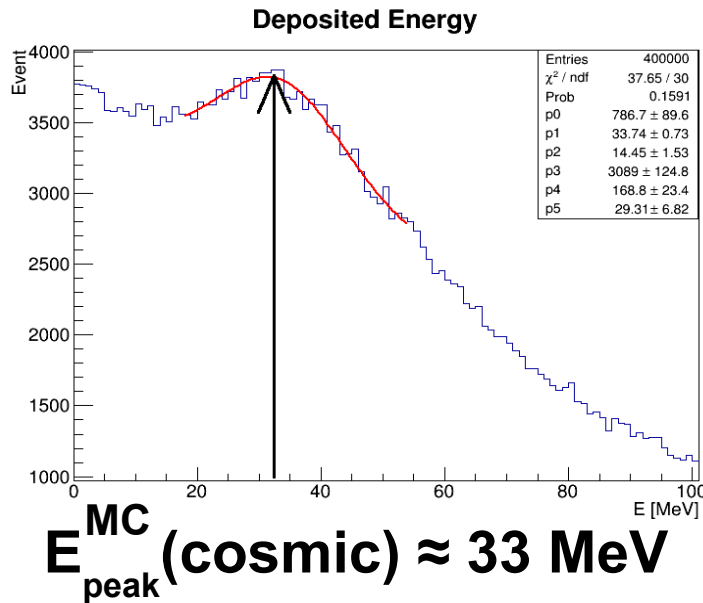

$$\text{ENE} = \sigma_{\text{cal}} \times \text{Price}_{\text{ADC}}$$

The light output is measured by comparison of the signal from cosmic muons (A_{cosm}) with calibration signal (A_{cal}) (gain is eliminated)

$$N_{\text{cosm}} (\text{ph.e.}) = (C_{\text{cal}} \times U_0 / e) \times (A_{\text{cosm}} / A_{\text{cal}})$$

$$\text{LO} = N_{\text{cosm}} / E_{\text{peak}}^{\text{MC}} / (\text{APD gain} = 50) / (S_{\text{APD}} [\text{cm}^2])$$

$$\text{LO} = 26 \text{ ph.e.} / \text{MeV} / \text{cm}^2$$

ENE(Csl(pure) + 1 APD)

1 small APD+6*6*30cm³ Csl Crystal

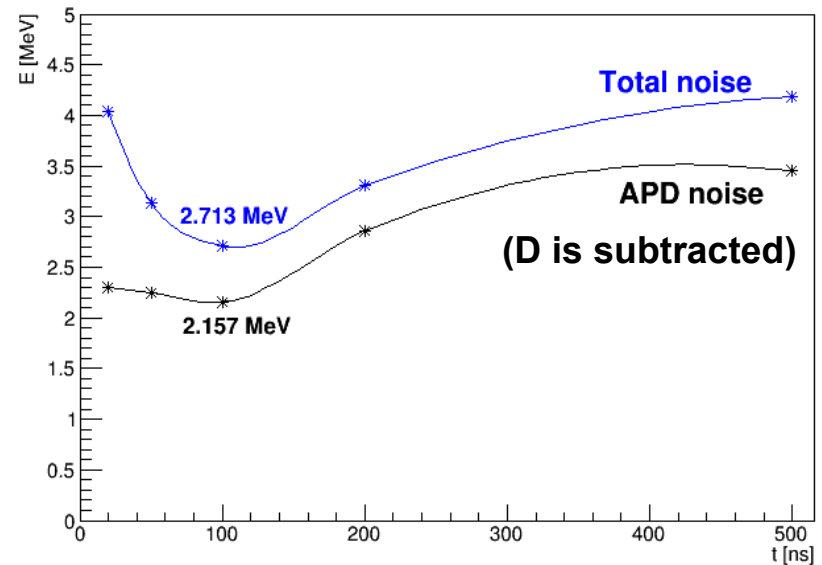

1 large APD+6*6*30cm³ Csl Crystal

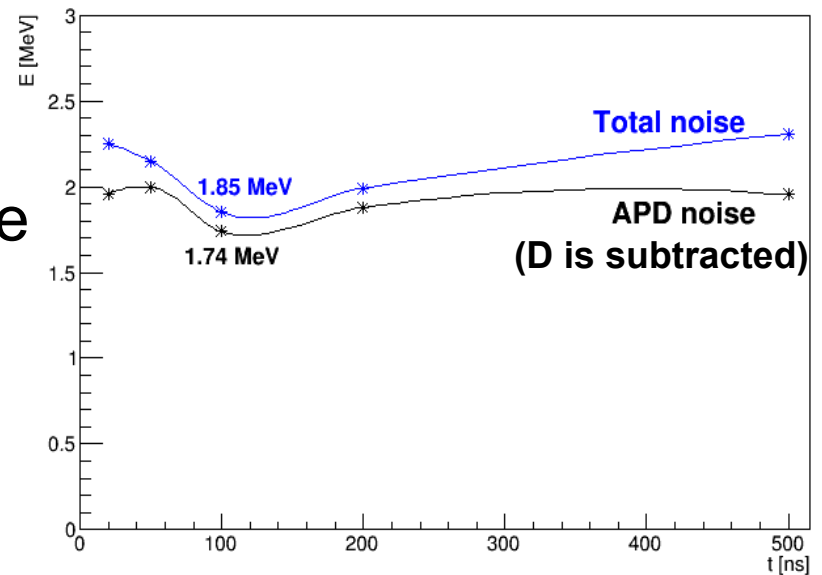

Csl(pure) crystal of $6 \times 6 \times 30 \text{ cm}^3$ size is wrapped by white teflon film and aluminized mylar, APD is attached to the $6 \times 6 \text{ cm}^2$ side by optical grease OKEN-6262A .

ENE(CsI(pure) + 2 APD's)

1 large APD+6*6*30cm³ CsI Crystal

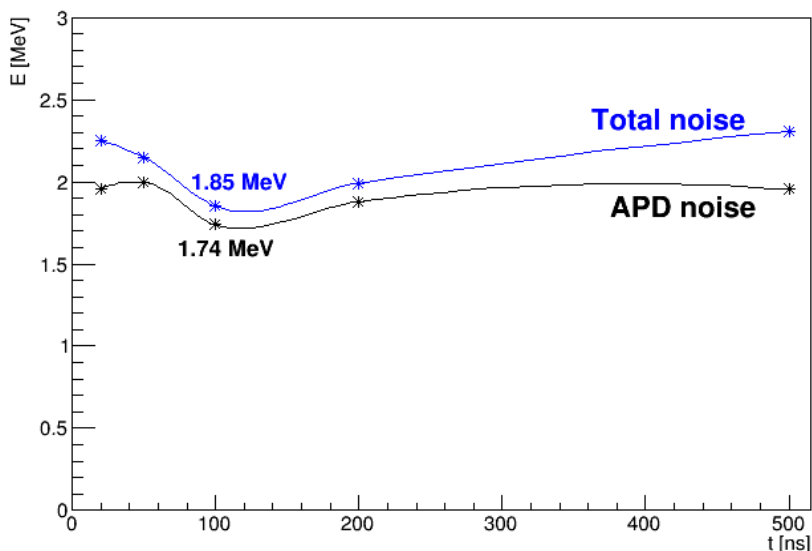

1 APD → 2 APD's



2 large APD+6*6*30cm³ CsI Crystal

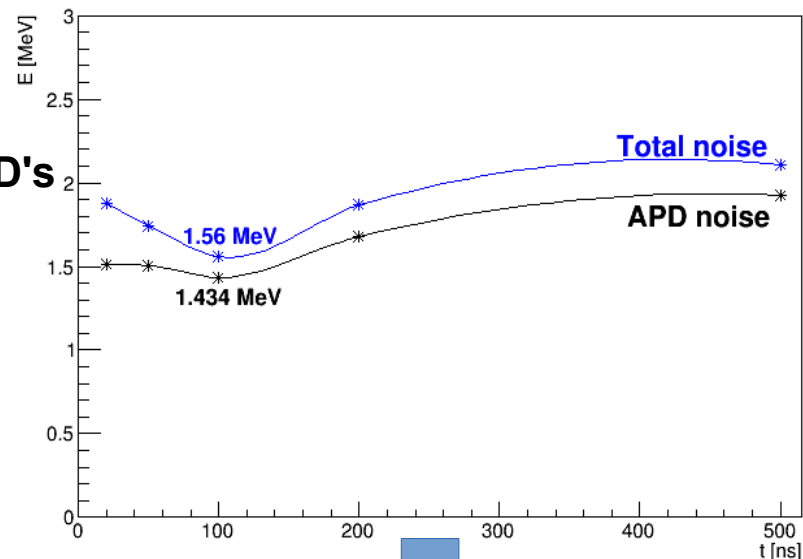

new 200µm teflon

2 large APD+6*6*30cm³ CsI Crystal+200µm Teflon

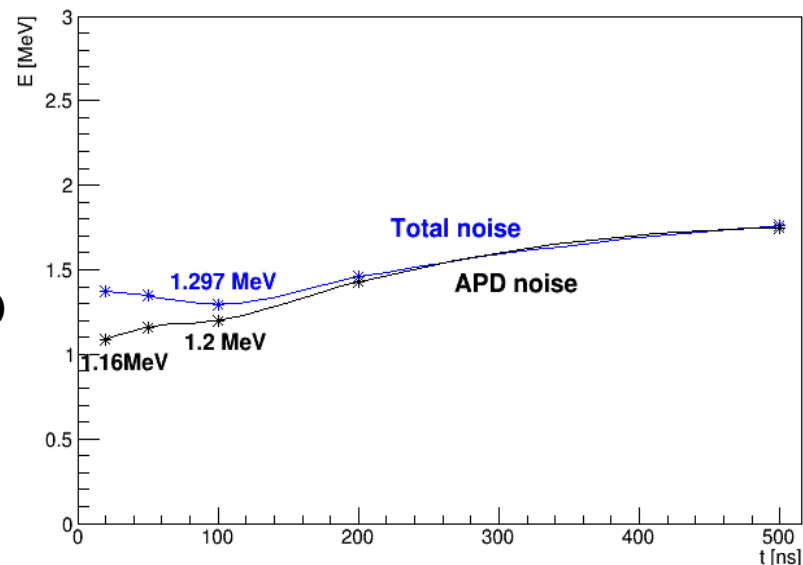

With 2 APD's we expect the decrease of ENE by a factor of $\sqrt{2}$, however we observe that ENE is reduced only by 1.2. It is explained that 1 APD has quite large dark current (26 nA) in comparison with the average one (8 nA).

We observed the improvement of the LO when we changed old teflon to the new one of 200 µm thickness

2 large APD's vs. 2 small APD's

2 large APD+6*6*30cm³ CsI Crystal+200um Teflon

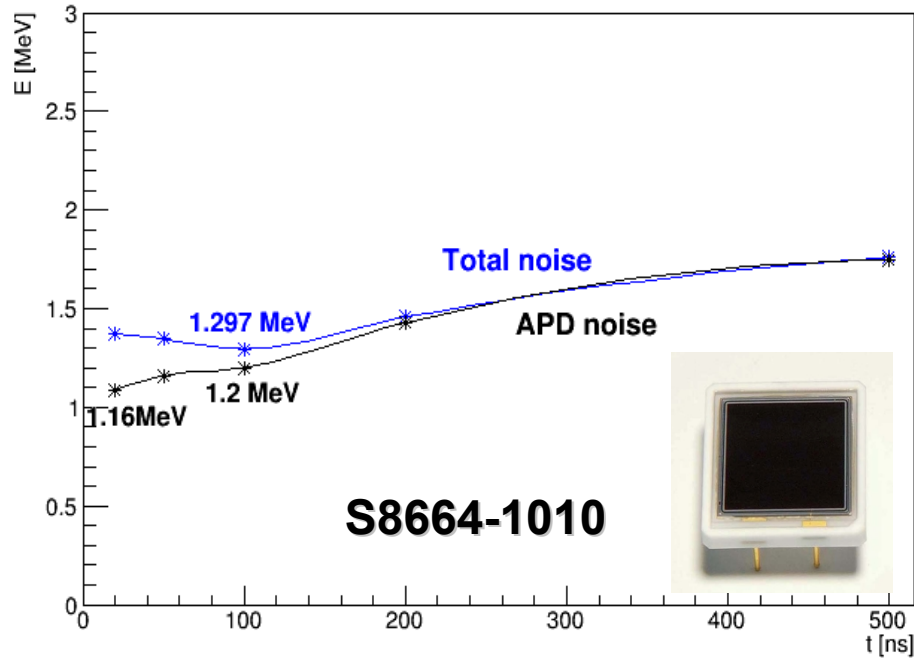

2 small APD+6*6*30cm³ CsI Crystal+200um Teflon

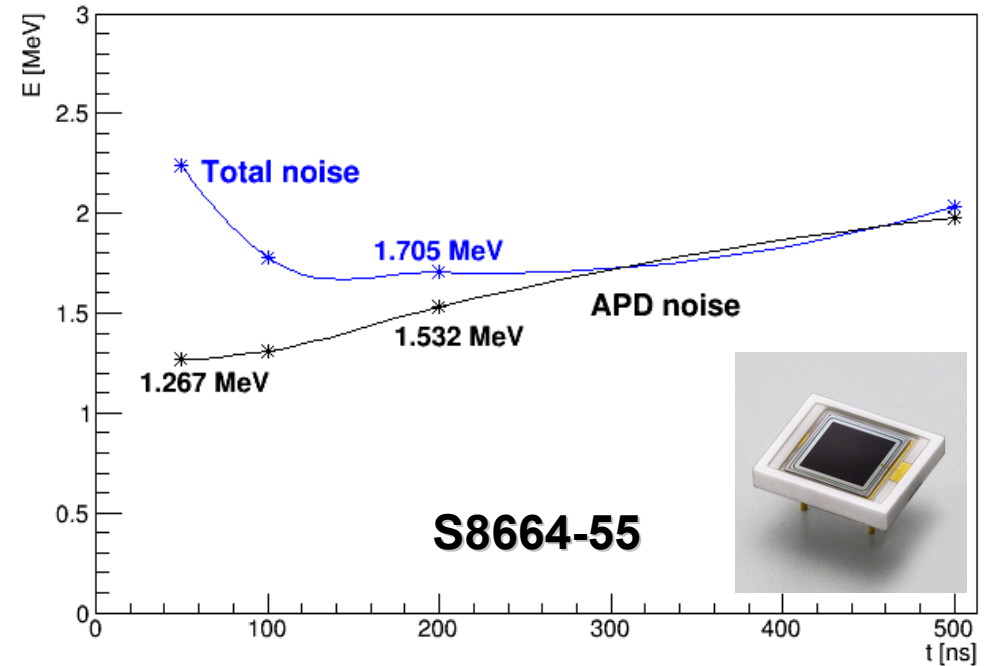

Light collection efficiency for the counter with S8664-55 APD is 4 times smaller, than for the counter with S8664-1010, but the thermal noise component is also smaller by a factor of $C_{APD}(\text{large}) / C_{APD}(\text{small}) \approx 3.5$

- ENC of the spectrometric channel with APD (S8664-55 and S8664-1010) and its components have been studied. We found that the additional noise (**D**) strongly varies with the shaping time. Measured ENC agrees with the theoretical expectations, further decrease of the thermal noise (R_s) is possible.
- Light output (LO) and equivalent noise energy (ENE) of the counter based on the actual size CsI(pure) crystal and 1 – 4 APD's (1 – 2 S8664-1010; 1 – 4 S8664-55) were measured:
 - LO = 26 ph.e./MeV/cm²**
 - ENE(2 S8664-1010 APD's (same I_{dark})) = 1.1 MeV;**
 - ENE(4 S8664-1010 APD's (same I_{dark})) = 0.8 MeV;
 - ENE(2 S8664-55 APD's) = 1.7 MeV;**
 - ENE(4 S8664-55 APD's) = 1.2 MeV;**

Further study

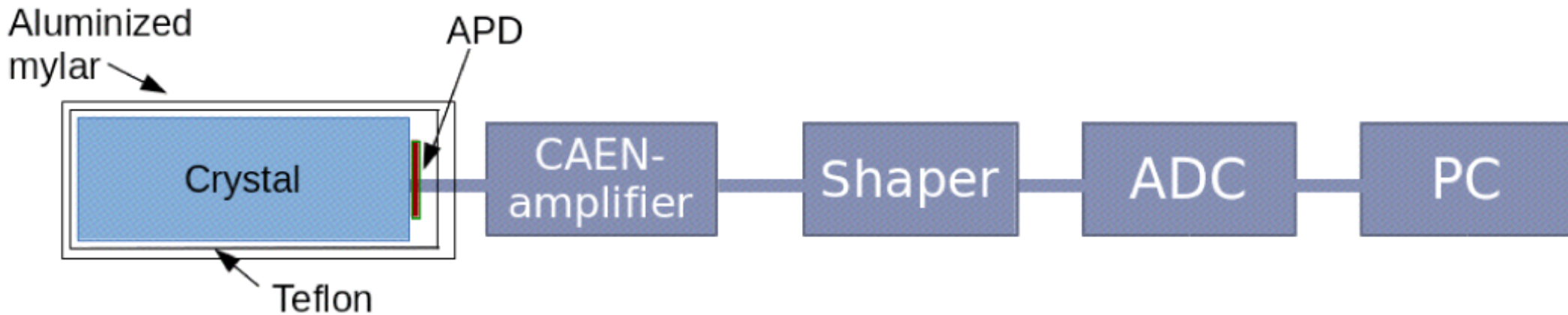

- Different types of optical greases.
- Teflon of different thickness.
- Temperature dependence of APD dark current and gain.
- Wavelength shifters.

Work with 3 types of Optical grease

	Refraction index	Transparency (@315nm)	Light collection efficiency
OKEN	1.453	85%	1
TSF451-50M	1.404	98% (company)	0.8544
BC-630	1.465	95% (company)	0.9533

OKEN is the best.

The light collection efficiency was also obtained from the simulation (6*6*30 cm³ CsI +1 cm² APD)

Refraction index	Light collection efficiency	Transparency (@315nm)
1.453	1.754%	1
1.404	1.62%	0.925
1.465	1.782%	0.938

We can calculate transparency from our measurement.

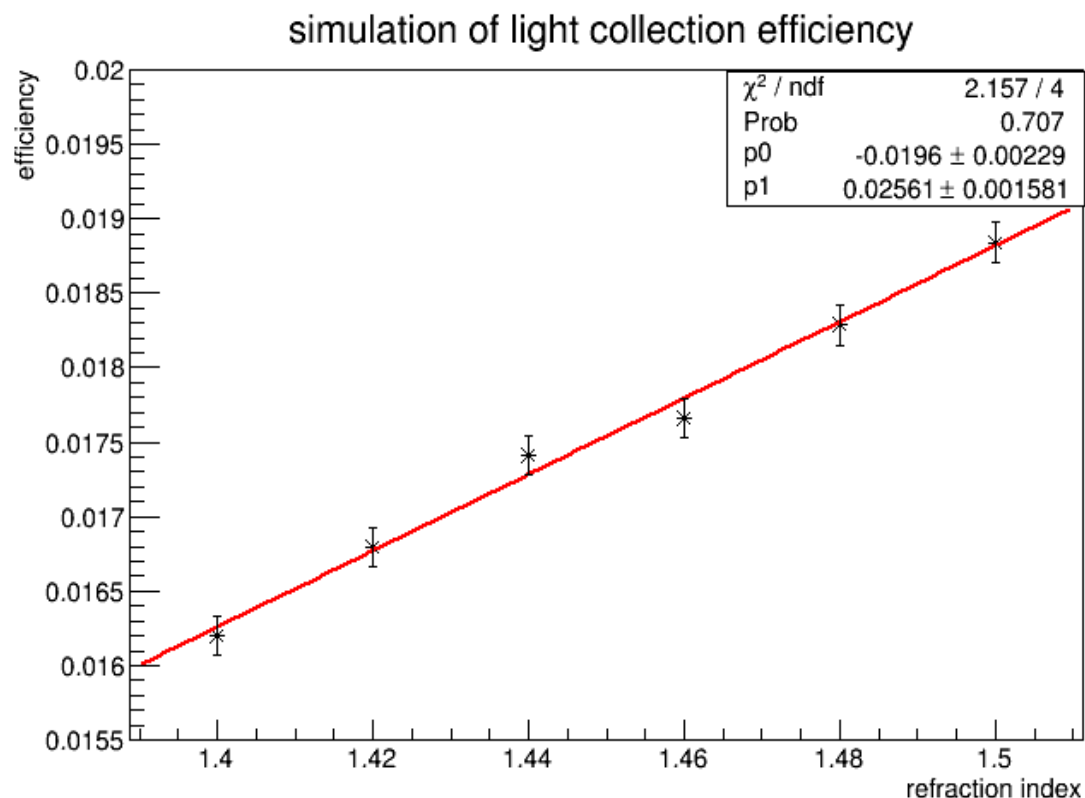

Teflon of different thickness

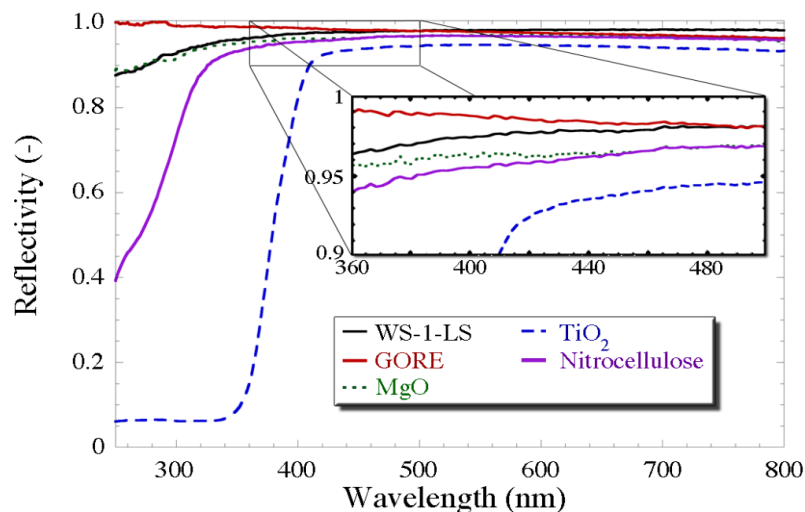

At UV range, Gore Teflon's performance is the best. So we studied the affect of Teflon's thickness.

We measured the position of cosmic peak.

Thicker Teflon, larger signal.

After 2 layers of 122 um, the signal almost gets saturated.

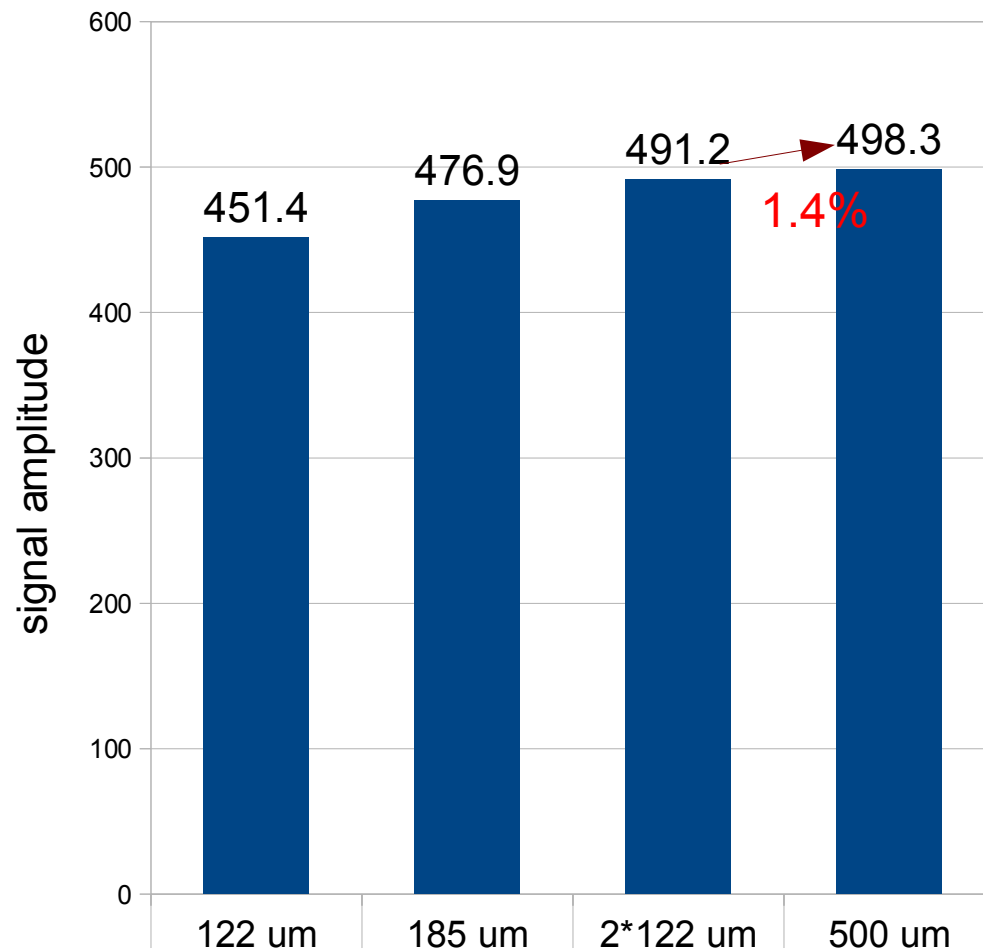

2 layers (~200 um) are enough.

thickness of teflon

Dark current' Temperature Dependence @ high biased Voltage

Dark current - Bias voltage

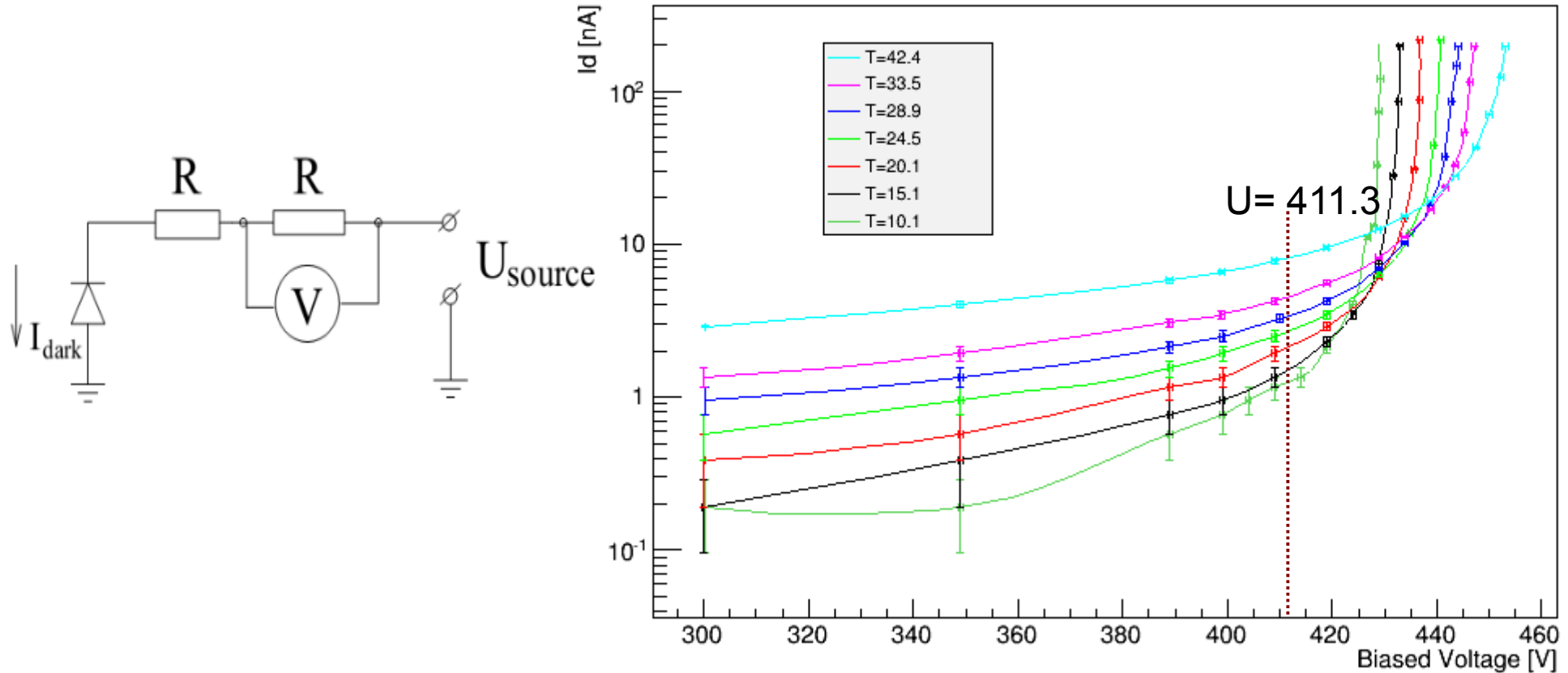

The temperature dependence of S8664-55 APD dark current is measured with accuracy $0.2\text{ }^{\circ}\text{C}$.

At the working point, the dark current is less than 10 nA within the wide temperature range ($10\text{-}43^{\circ}\text{C}$).

Gain's Temperature Dependence

Gain - Bias voltage

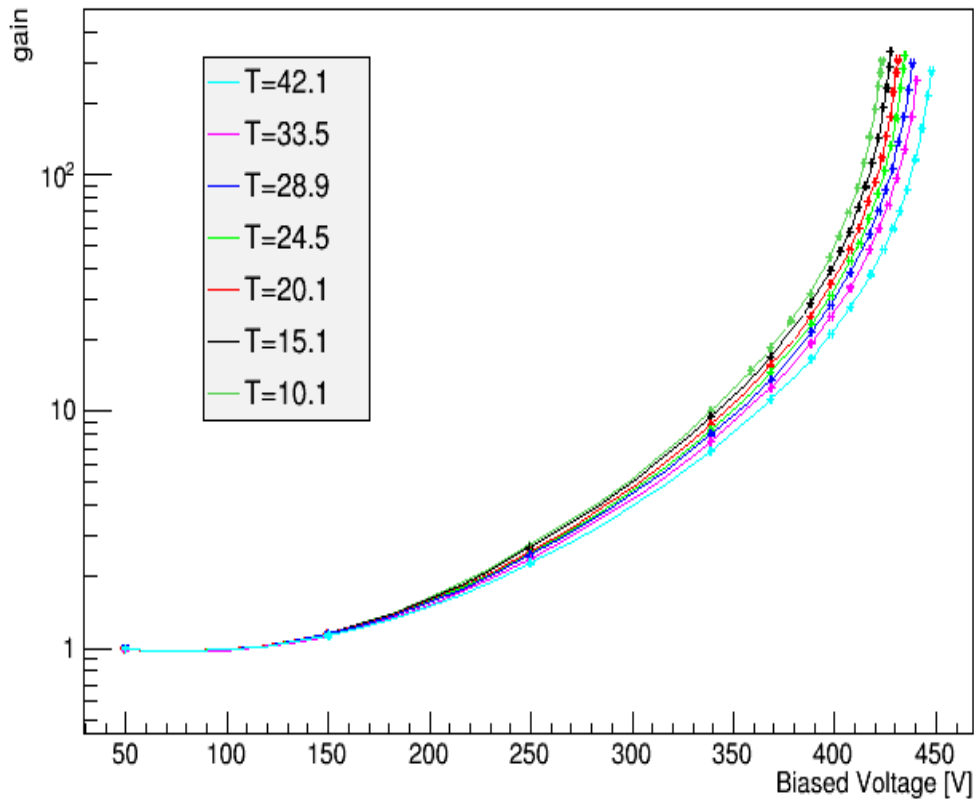

Keeping stability of APD gain within 1% requires an accuracy of temperature less than 0.3°C.

Gain - Bias voltage

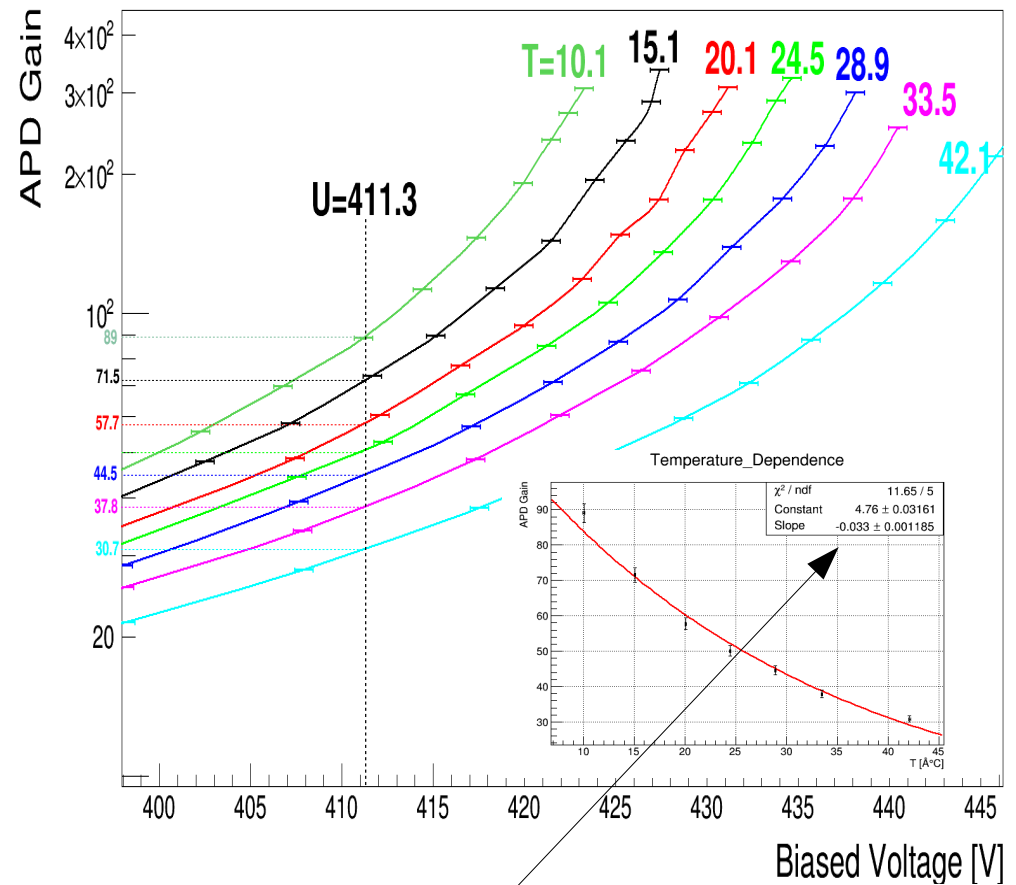

$(d\text{Gain}/dT) \cdot (1/\text{Gain}) = 3.3\% / ^\circ\text{C}$

Study with wavelength shifting plates (WLS)

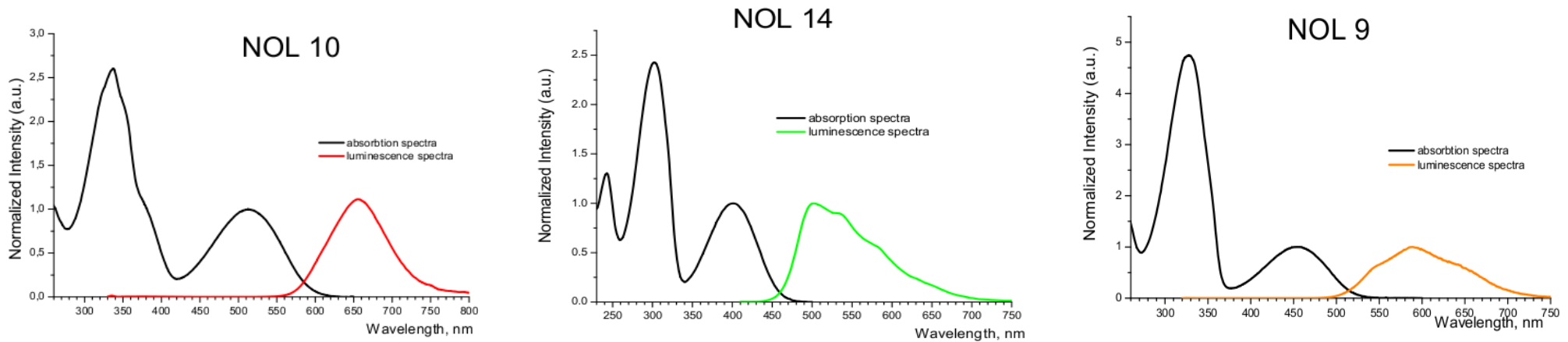

Based on the nanostructured organosilicon luminophores (NOL) from LumInnoTech Company, the WLS plates were developed for us (60*60*2 mm³).

The absorption and emission spectra of these NOL's match our need well.

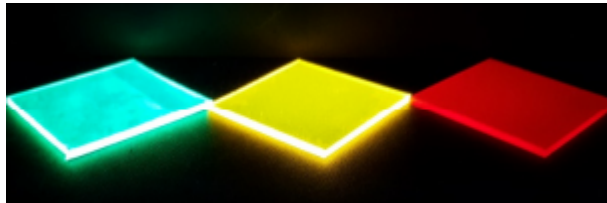

According to Hamamatsu, the improvement in QE if we shift light UV->visible is ~2.

■ Quantum efficiency vs. wavelength

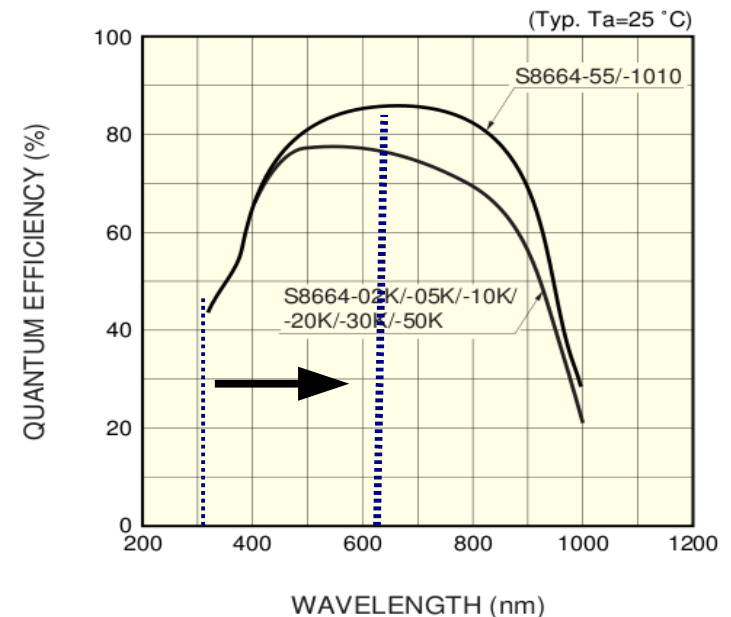

With WLS plats we get standard QE APD.

Results with WLS plates

We measure position of the cosmic peak.

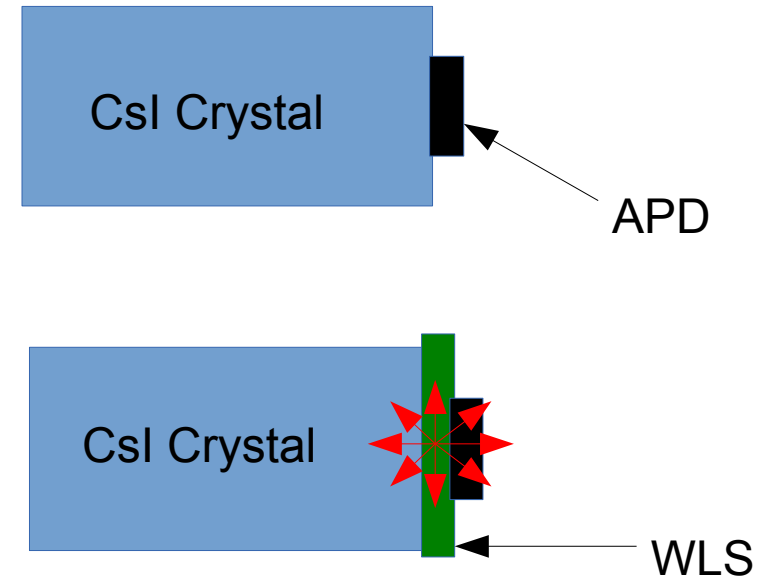
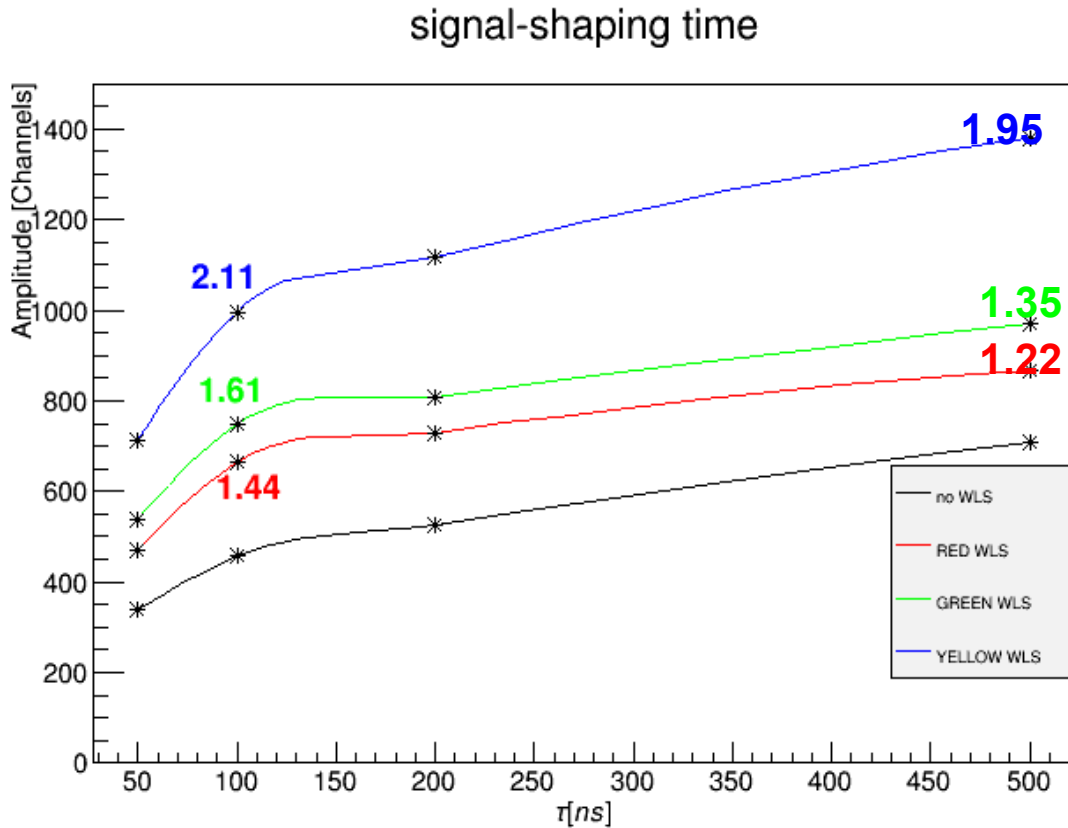

By this way, we can improve ENE.

The yellow WLS is the best.

ENE with WLS plates

noise-shaping time

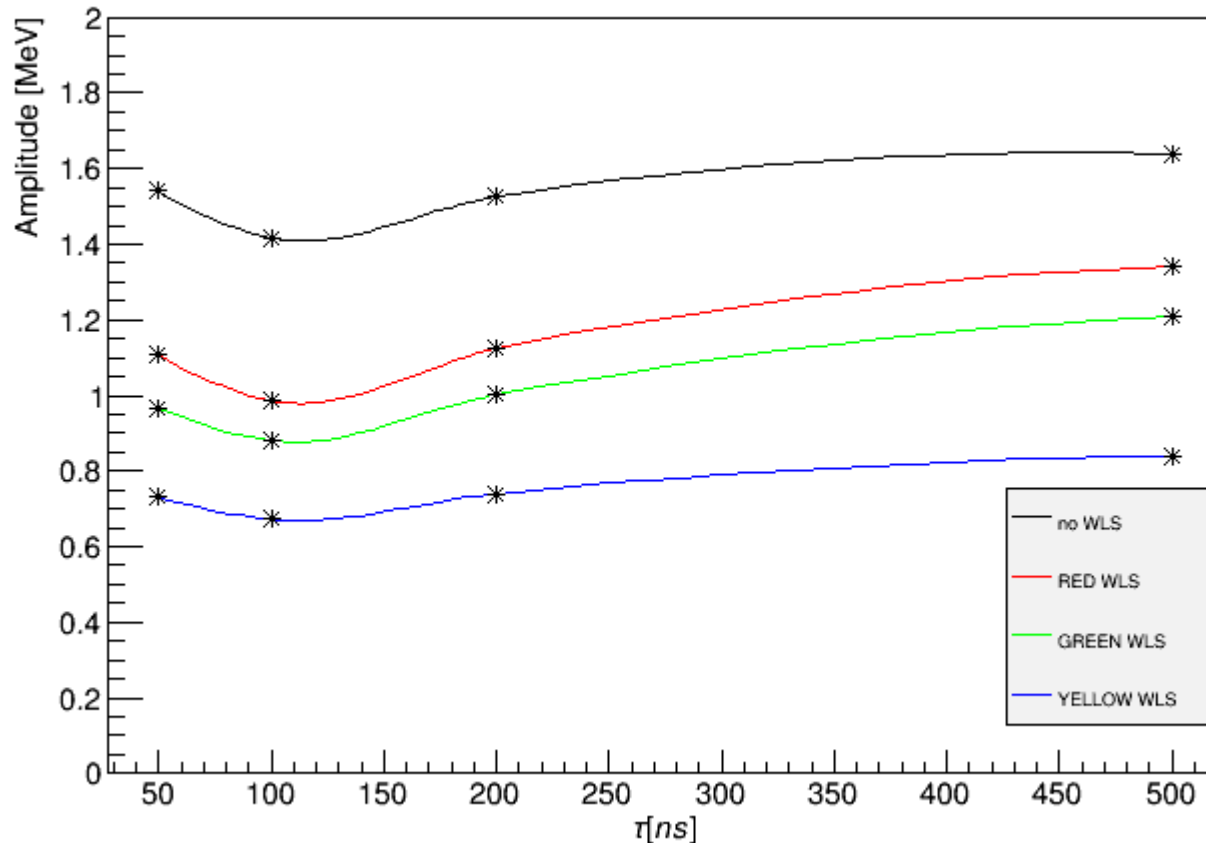

We studied the counter with 2 large APDs (S8664-1010). By yellow WLS plate we get ENE \rightarrow 0.6 MeV.

One of our APD has x3 dark current, with identical APDs, the ENE can be reduced to 530 keV.

Before, 4 small APDs' noise 1.2 MeV now can be reduced to 570 keV.

Summary

- Among all three types of optical greases, OKEN is the best.
- Teflon with thickness of 200 μm is enough.
- Yellow WLS provides largest signal increase of a factor 2.1
- Measured ENE of the counter with 2 Large APD \rightarrow 600 keV.

Future Plans

- Measure ENE of the counter with 4 small APD (expected ENE: 570 keV).
- Optimize pre-amplifiers.
- Special geometry of WLS plate.

Thank you !