

New precise measurement of the hyperfine splitting of positronium

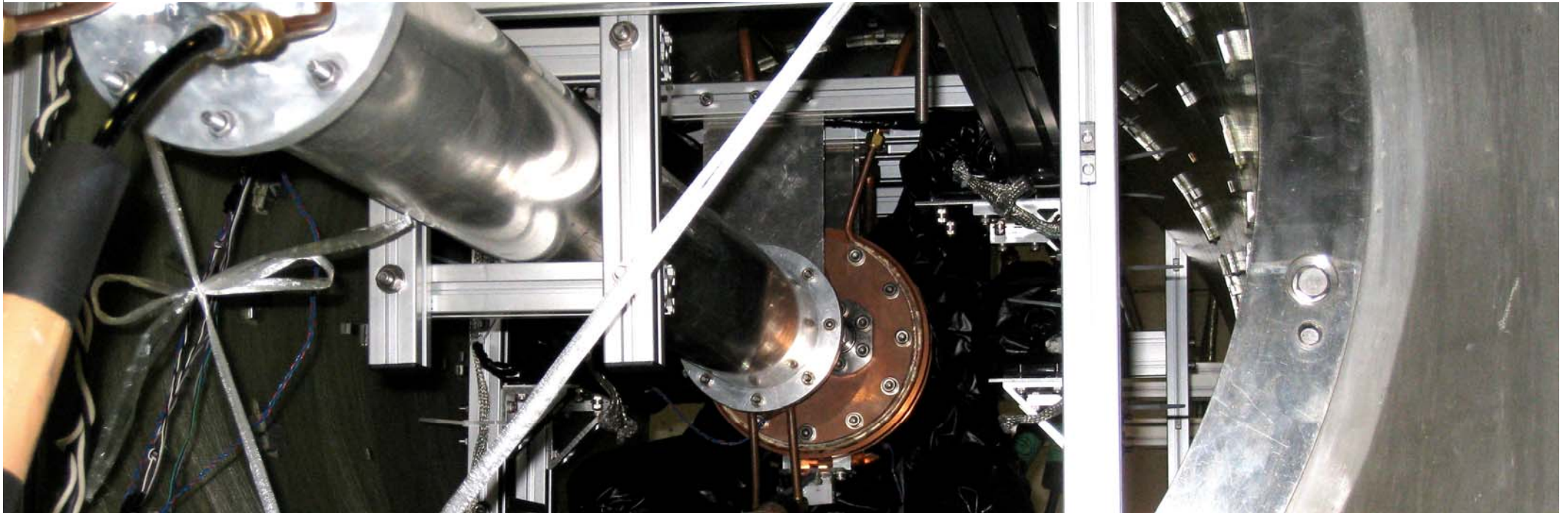

Akira Ishida

The University of Tokyo

Fundamental Constants Meeting 2015

06/02/2015 Eltville, Germany

Members

A. Ishida, T. Namba, S. Asai, T. Kobayashi

Department of Physics and ICEPP, The University of Tokyo

H. Saito

Department of General Systems Studies, The University of Tokyo

M. Yoshida, K. Tanaka, A. Yamamoto

High Energy Accelerator Research Organization (KEK)

Warm thanks to facilities and the entire members
of the Cryogenics Science Center at KEK

Outline

- Positronium Hyperfine Splitting (Ps-HFS)
- Material effect and Ps thermalization
- Our New Experiment
- Analysis and Results
- Prospects & conclusion

Physics Letters B 734 (2014) 338–344



Contents lists available at [ScienceDirect](#)

Physics Letters B

www.elsevier.com/locate/physletb



New precision measurement of hyperfine splitting of positronium

A. Ishida^{a,*}, T. Namba^a, S. Asai^a, T. Kobayashi^a, H. Saito^b, M. Yoshida^c, K. Tanaka^c,
A. Yamamoto^c



Positronium (Ps)

- Bound state of an electron (e^-) and a positron (e^+)
- Precision test of bound-state Quantum ElectroDynamics (QED).

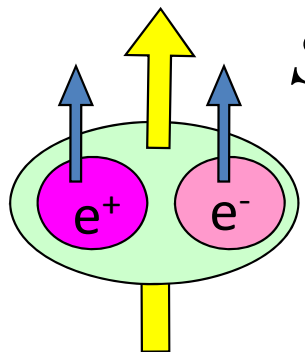
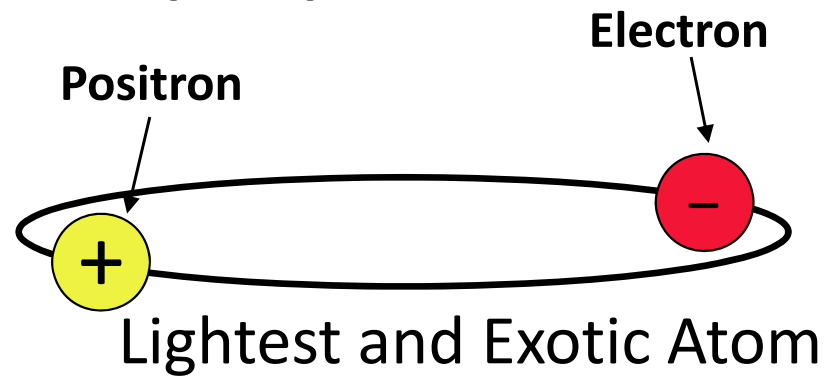

$\vec{S} = 1$ (Triplet)

Ortho-positronium (o-Ps)

Spin=1 The same quantum number as photon

o-Ps $\rightarrow 3\gamma$ (, 5γ , ...)

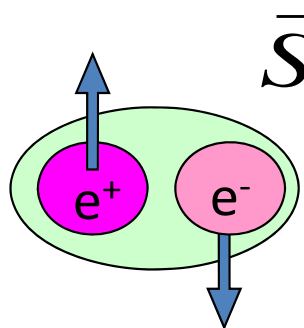

$\vec{S} = 0$ (Singlet)

Para-positronium (p-Ps)

Spin=0 pseudo-scalar

p-Ps $\rightarrow 2\gamma$ (, 4γ , ...)

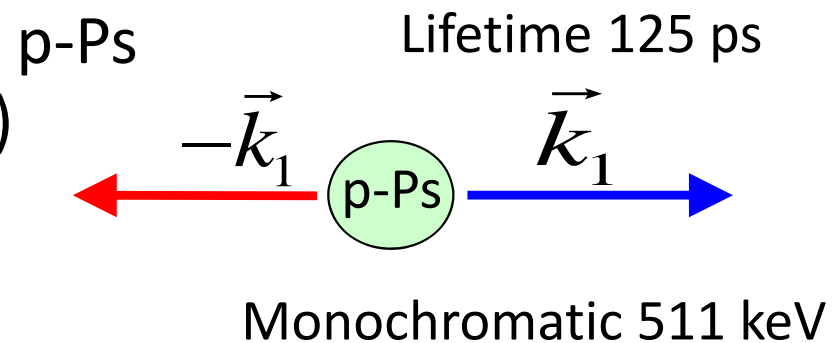
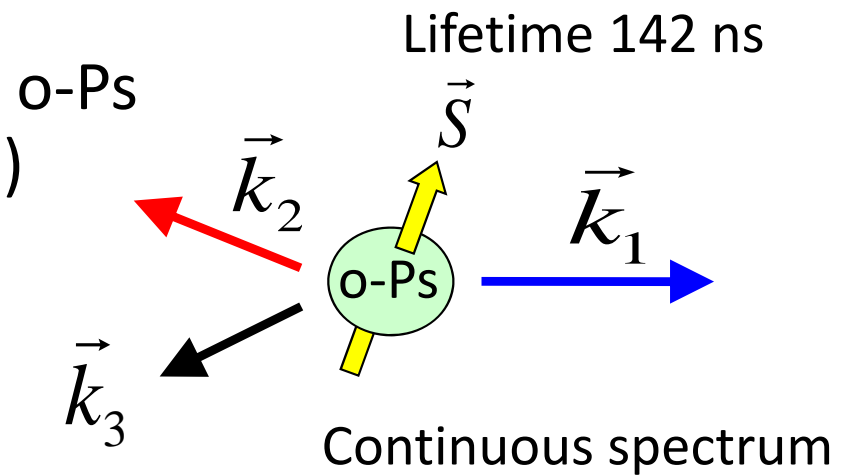

Positronium Hyperfine Splitting (Ps-HFS)

Energy difference between two spin eigenstates of the ground state Ps
 → Ps-HFS (203 GHz)

$$\vec{\mu} = \frac{e}{2m} \vec{\sigma} \quad \text{spin-spin interaction}$$

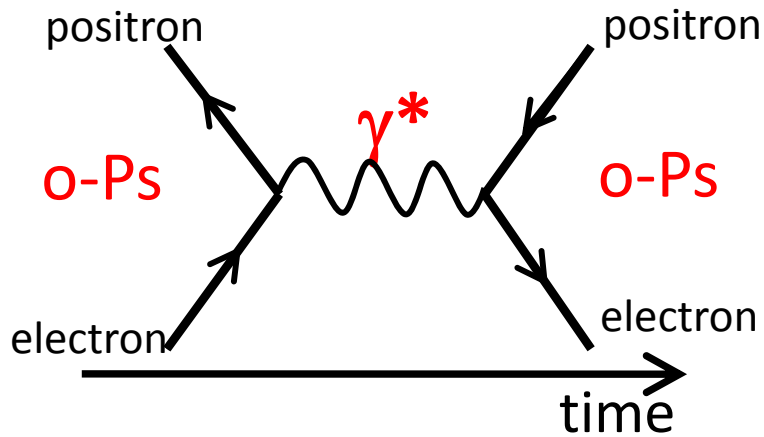

Quantum oscillation effect is also large (40%)

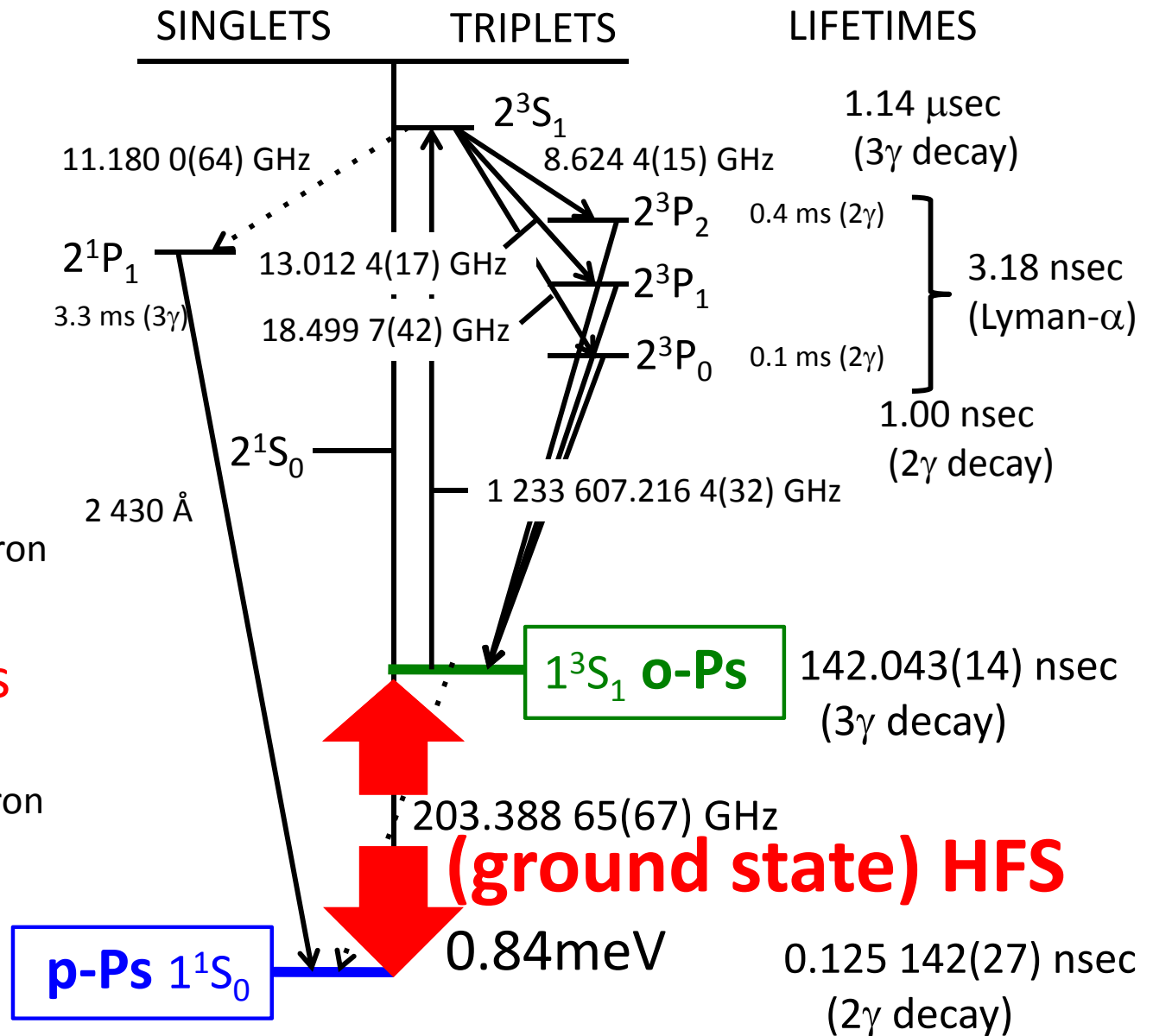

Discrepancy Between Previous Experiments and Theory

Previous experimental average

Theory (2014)

PRD 89 (2014) 111301(R)
PRA 90 (2014) 042502

Previous experimental results are consistently lower than theory.

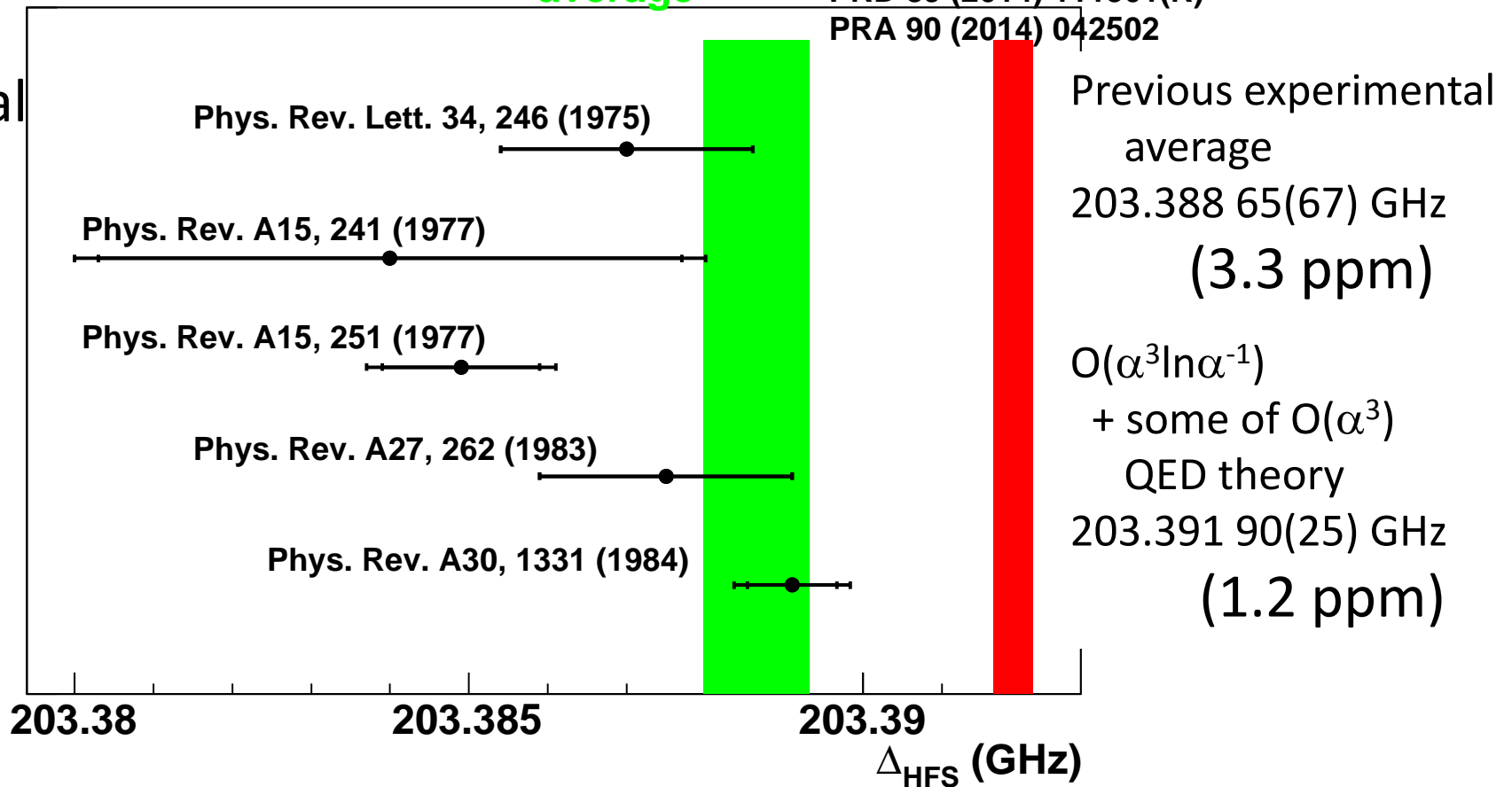

16 ppm (4.5 σ) significant discrepancy

Possible reasons for the discrepancy

- Common systematic uncertainties in the previous experiments

1. Non-uniformity of the magnetic field.

2. Underestimation of material effects. Unthermalized o- P_s can have a significant effect especially at low material density. *cf. o- P_s lifetime puzzle (1990's)*

We introduced new methods to reduce these systematic errors.

- Need new development on calculation of bound-state QED or New physics beyond the Standard Model.

Estimation of Material Effect in previous experiments

- Need material (in this case gas molecules) so that positron can get electron and form Ps \rightarrow Ps feels electric field of material

Strength of the Stark Effect

$\propto \sim$ Collision rate with surrounding molecules

\propto (Density of surrounding molecules) \times (Ps velocity v)^{3/5}

\rightarrow If the Ps velocity is constant (under assumption that Ps is well thermalized), the material effect is proportional to gas density.

\rightarrow The Previous experiments

Phys. Rev. A
1984 **30** 1331
Ritter, Egan, Hughes et al.

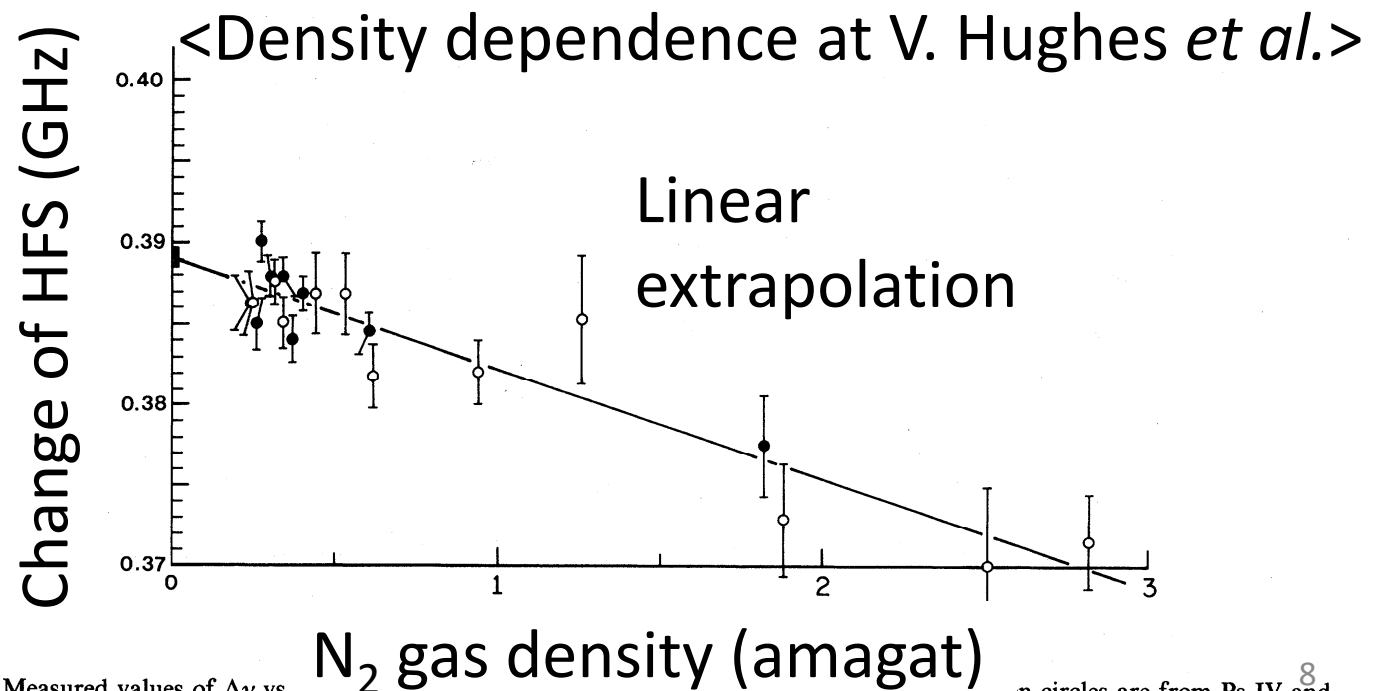

FIG. 7. Measured values of $\Delta\nu$ vs the closed circles are from the present work. The straight line is the best fit described in Eq. (14).

Evolution of Ps velocity

Strength of the Stark Effect

$\propto \sim$ Collision rate with surrounding molecules

\propto (Density of molecules) \times (Ps velocity $v(t)$)^{3/5}

Ps loses its kinetic energy and gets room temperature = Thermalization

It takes longer time to thermalize in lower density \rightarrow Linear extrapolation could be a large O(10ppm) systematic uncertainty

\rightarrow We measured Ps thermalization independently. Used obtained result for analysis of Ps-HFS measurement.

< Simulation of time evolution of Ps velocity in N₂ gas >

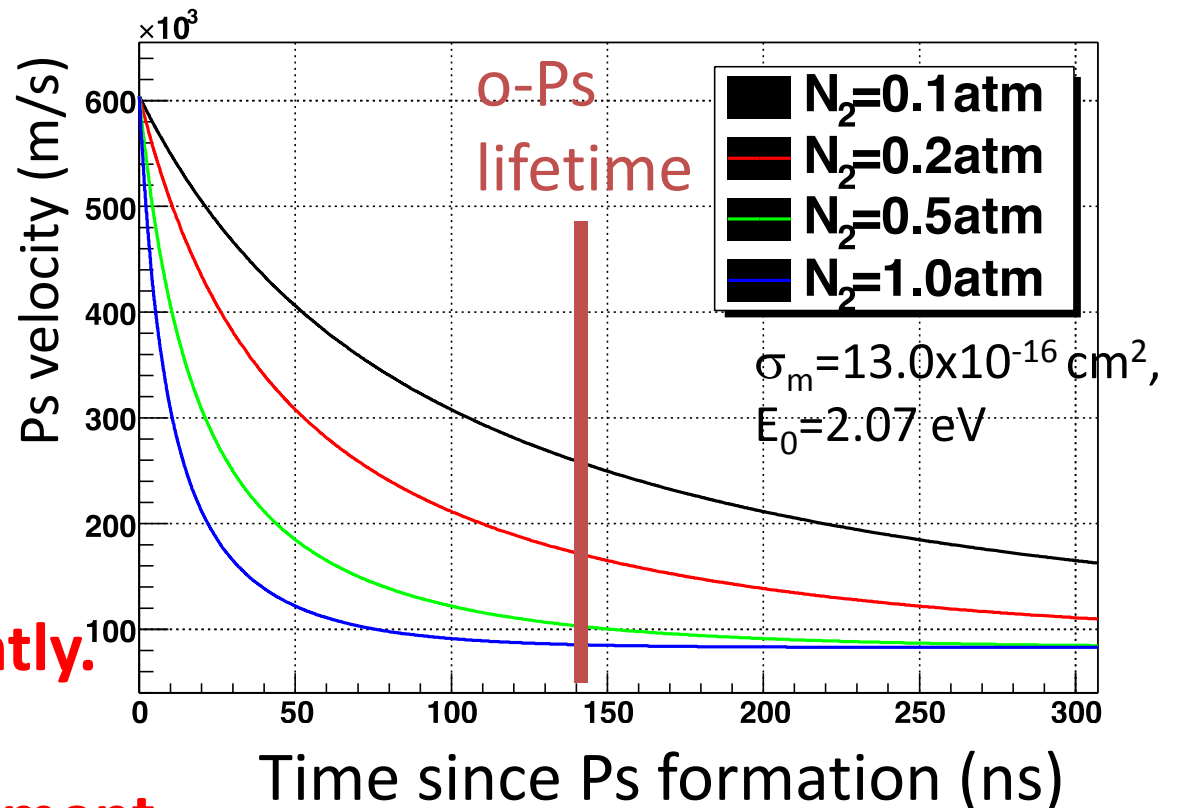

Experimental Technique

Indirect Measurement using Zeeman Effect

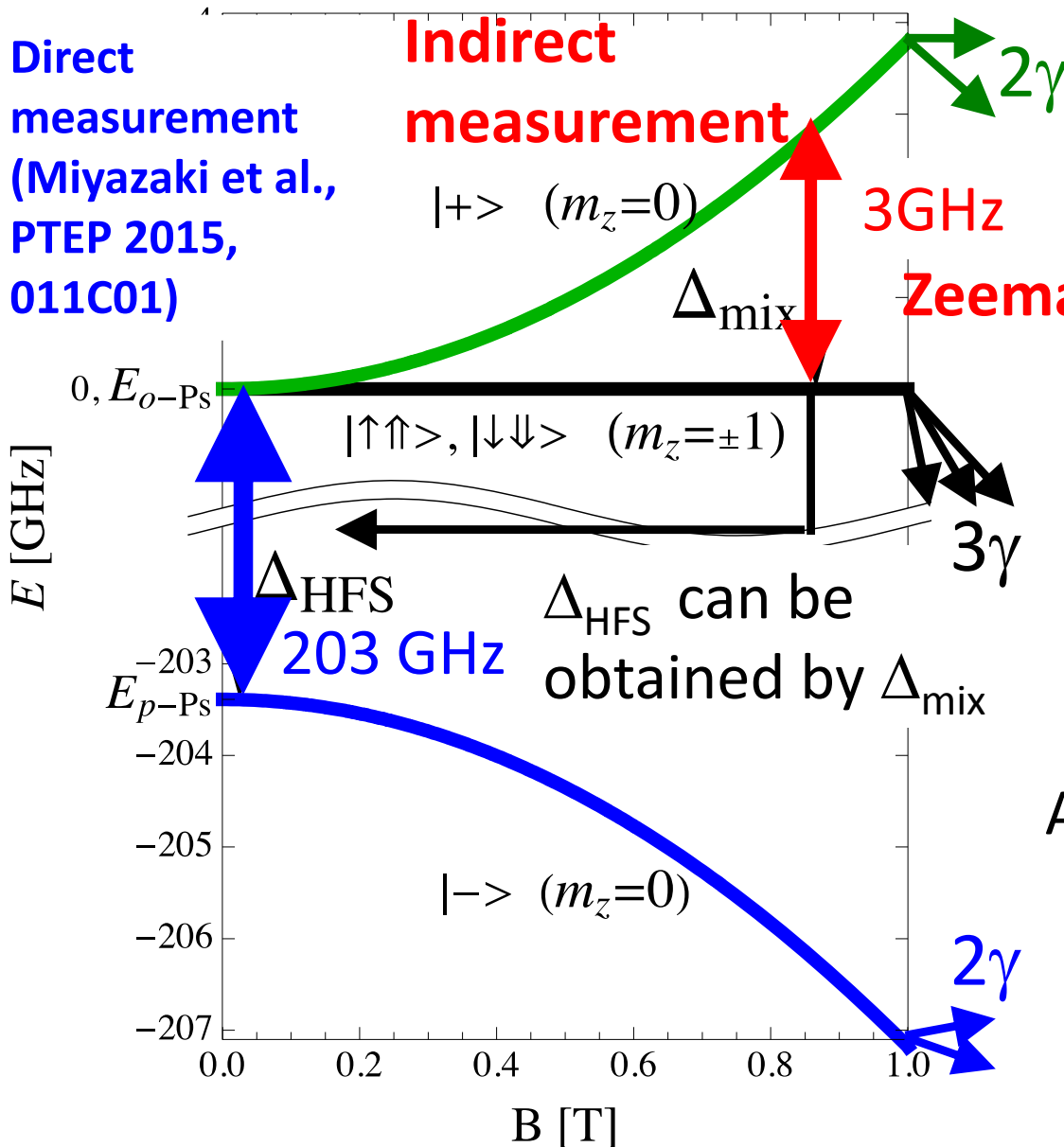

In a static magnetic field, the **p-Ps** state mixes with the **$m_z=0$** state of **o-Ps** (Zeeman effect).

→ **2γ -ray annihilation (511 keV monochromatic signal)** rate increases.

This increase is our experimental signal.

Approximately,

$$\Delta_{\text{mix}} \approx \frac{1}{2} \Delta_{\text{HFS}} \left(\sqrt{1 + 4x^2} - 1 \right)$$

$x = \frac{g' \mu_B B}{h \Delta_{\text{HFS}}}$. This is not precise enough, so we solve time evolution of density matrix.

Measurement @ KEK CSC (Jul 2010 – Mar 2013)

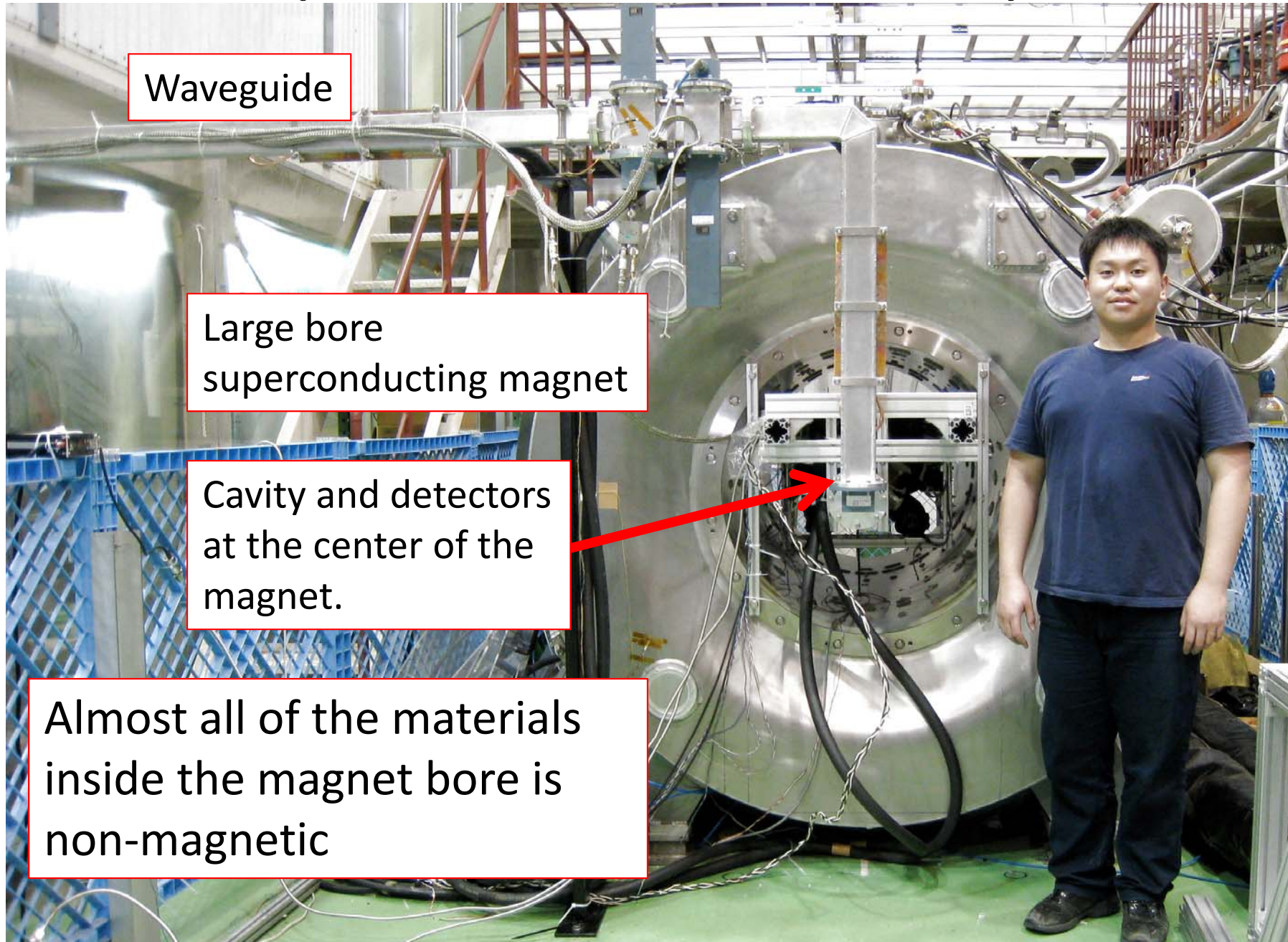

Our new Experiment

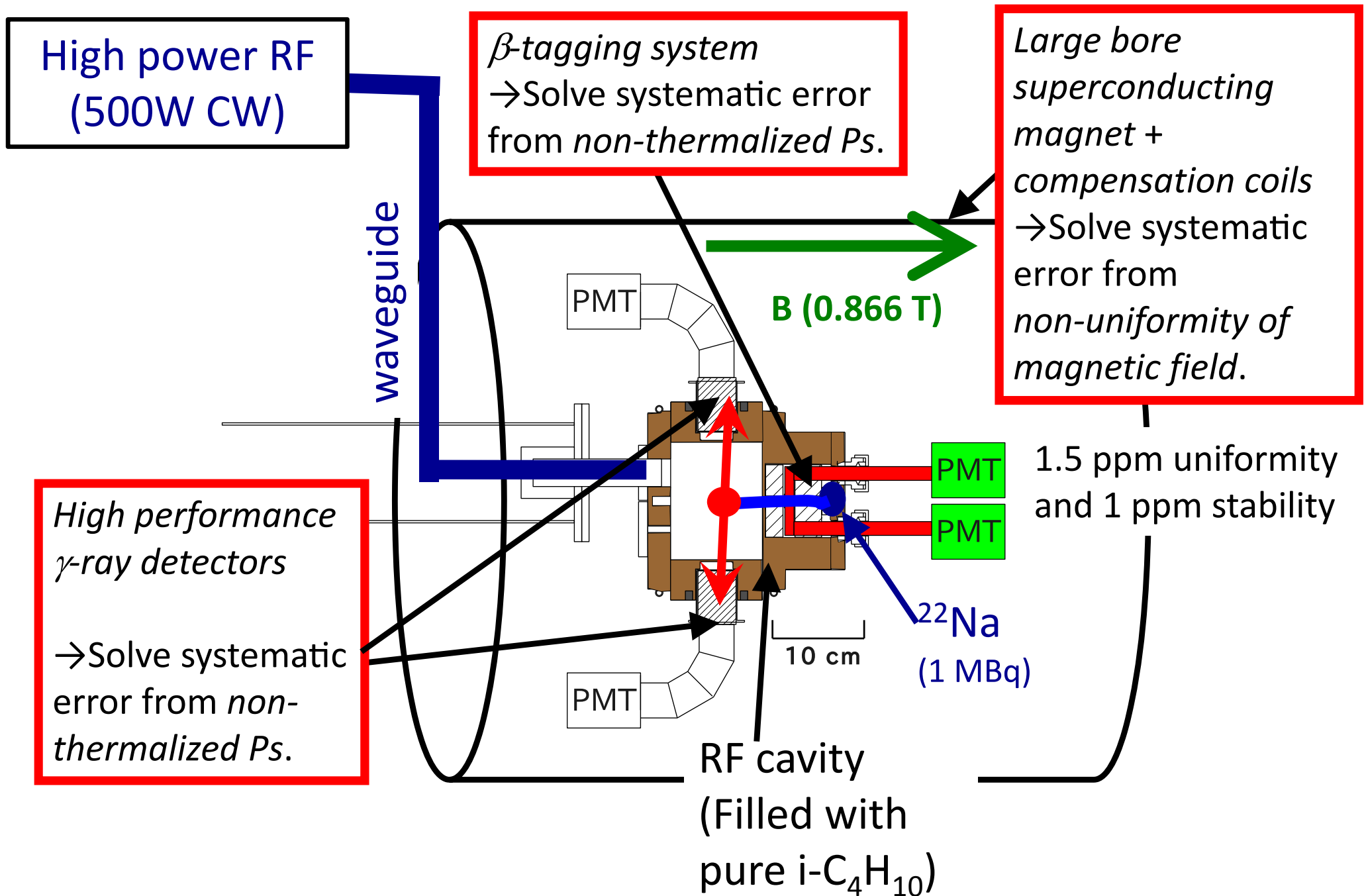

β -tagging system

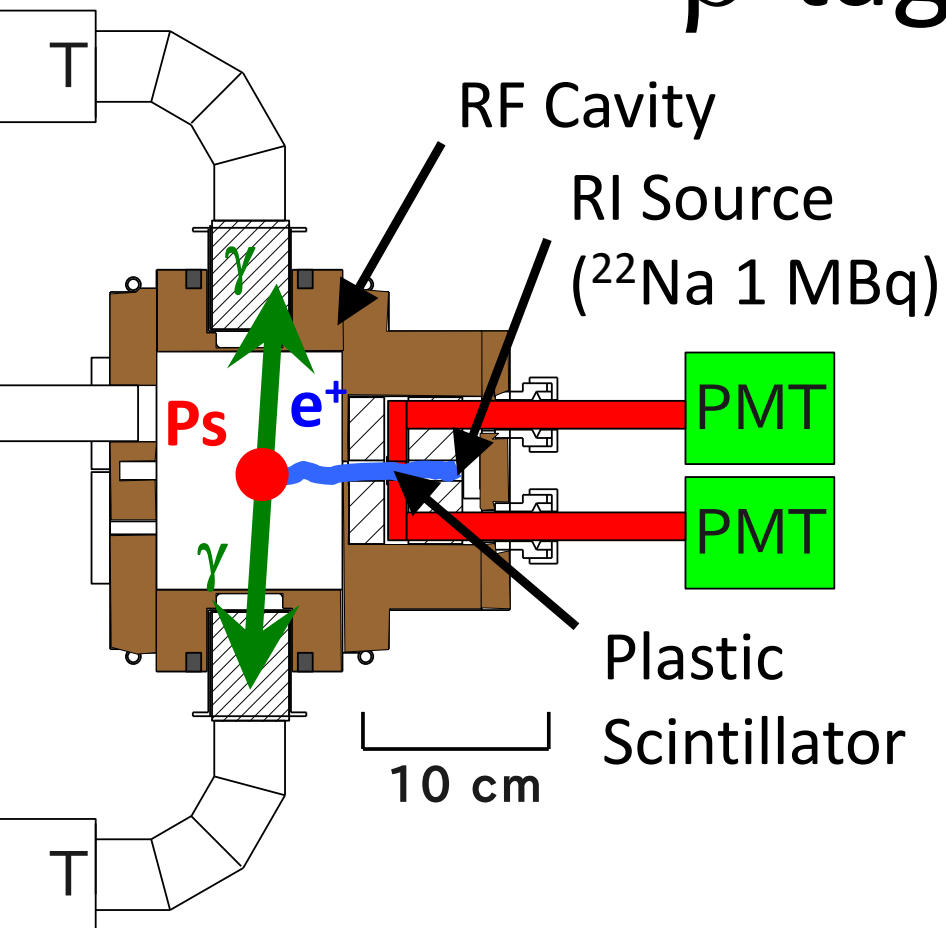

- Tag e^+ from the ^{22}Na by thin (0.1 mm) plastic scintillator.
→ $t=0$

- DAQ Trigger is made by coincidence of e^+ tag signal and γ -ray detection.
- Time difference of these signals is Ps life time of each event.

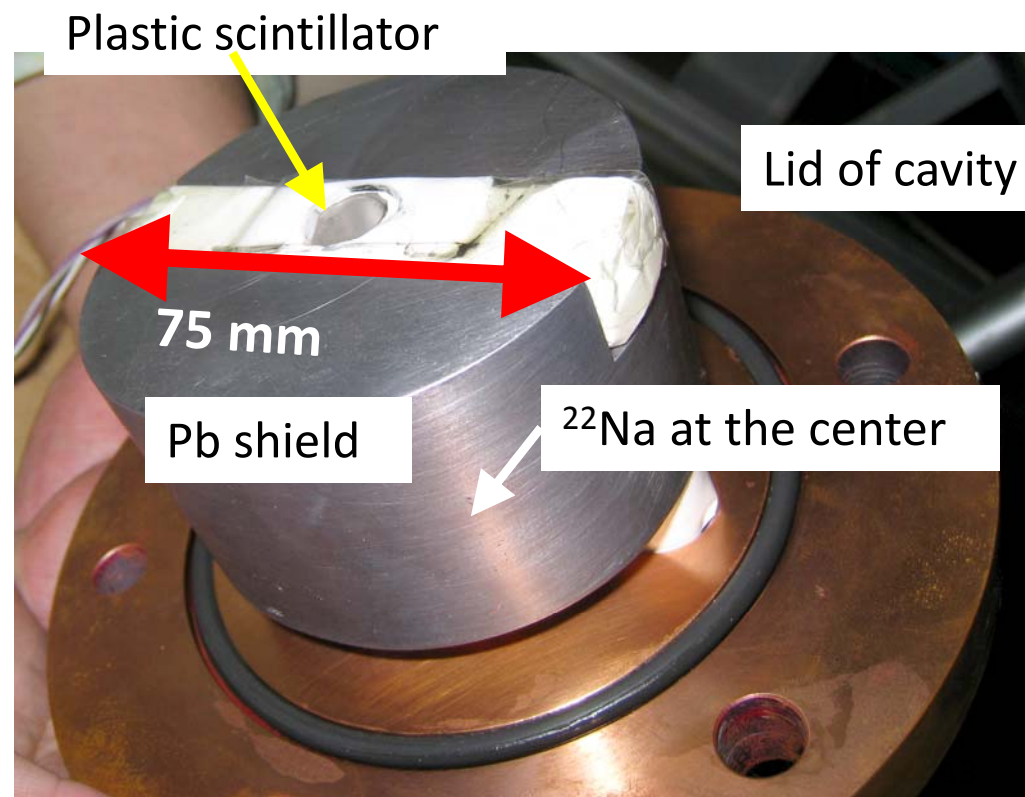

Timing spectra (RF-OFF)

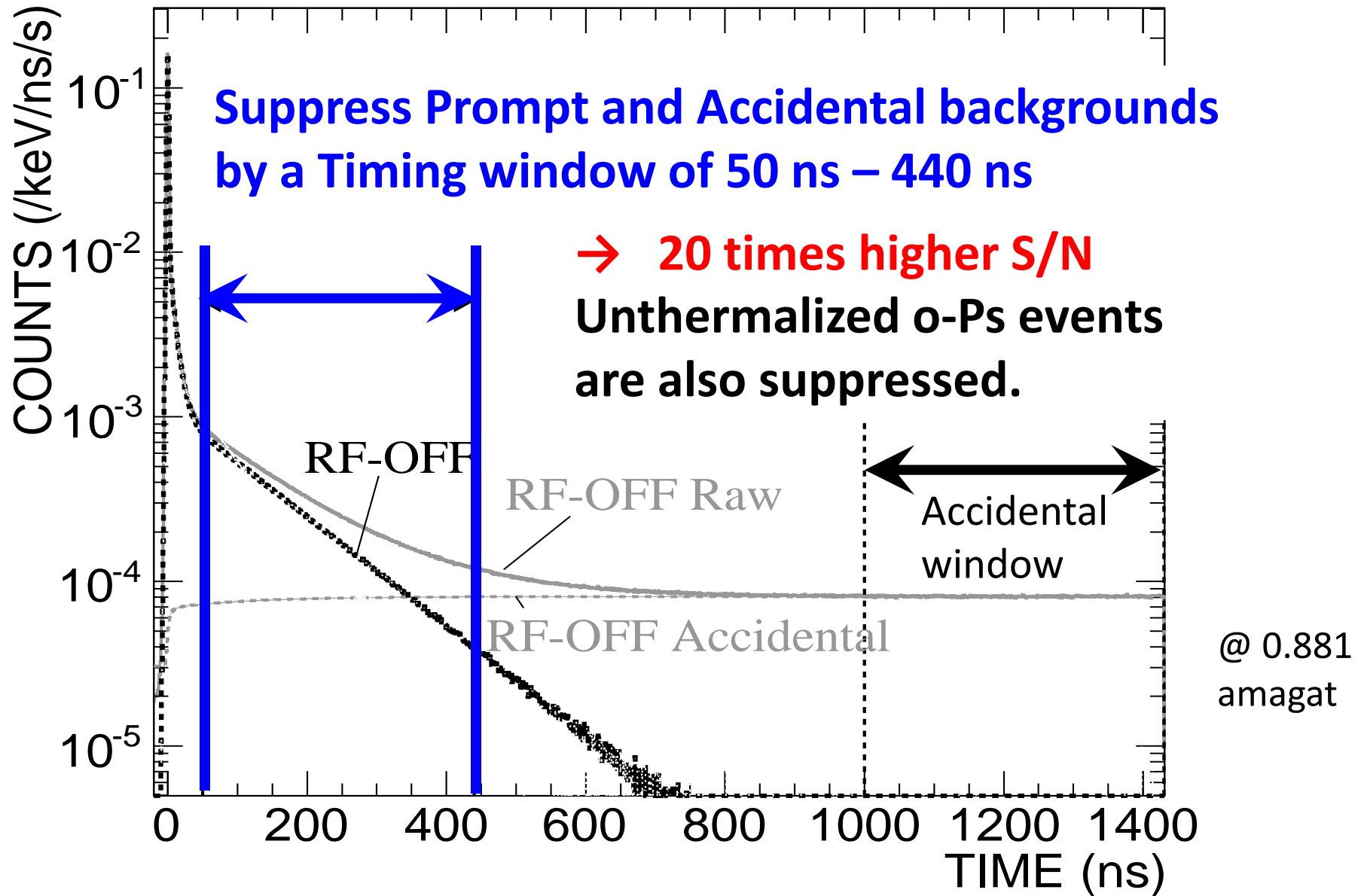

Timing spectra (RF-ON/OFF)

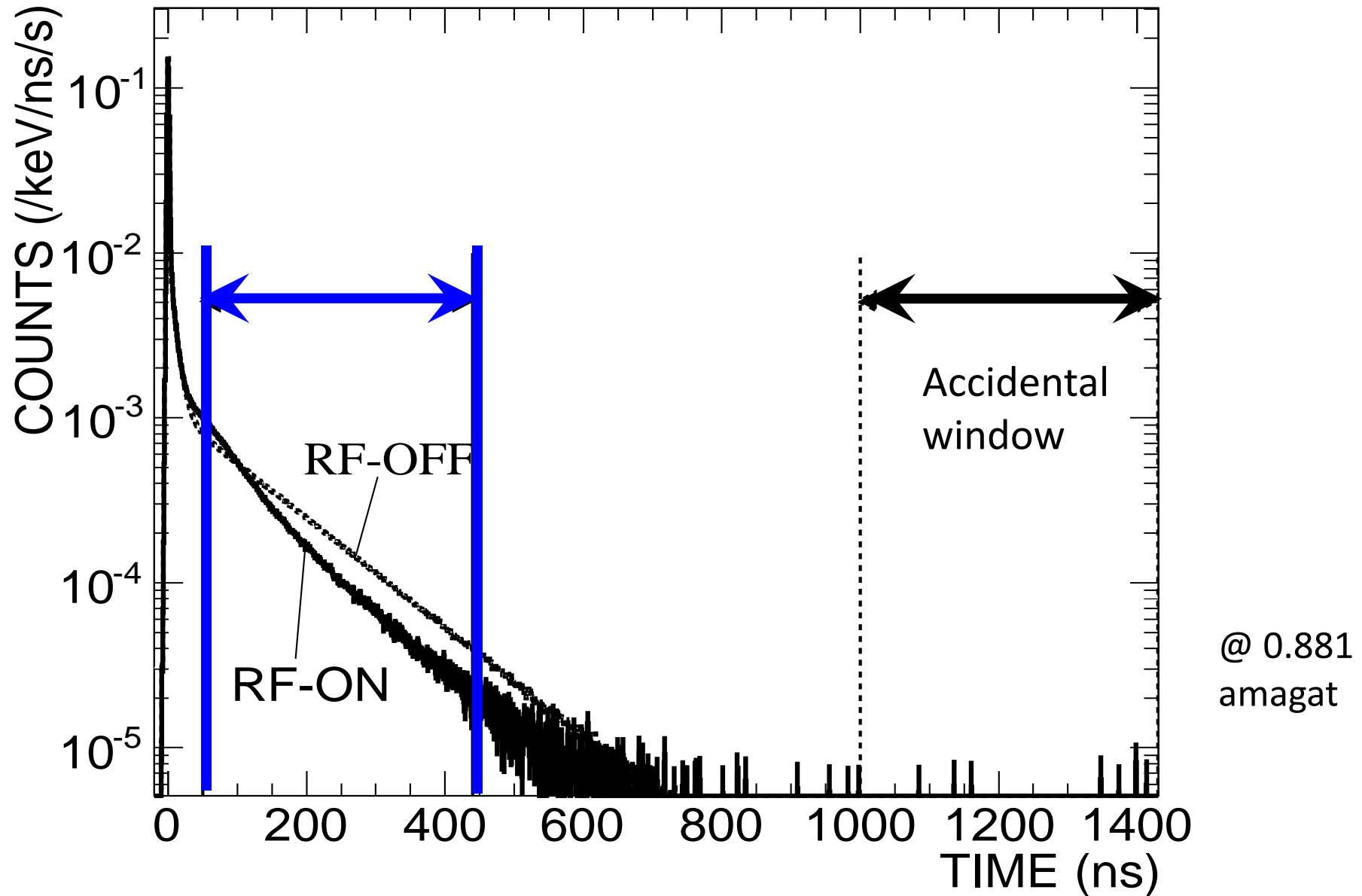

Lifetime is clearly shortened by RF due to the Zeeman transition.

Energy spectra

timing window 50 – 60 ns

511 keV $\pm 1\sigma$

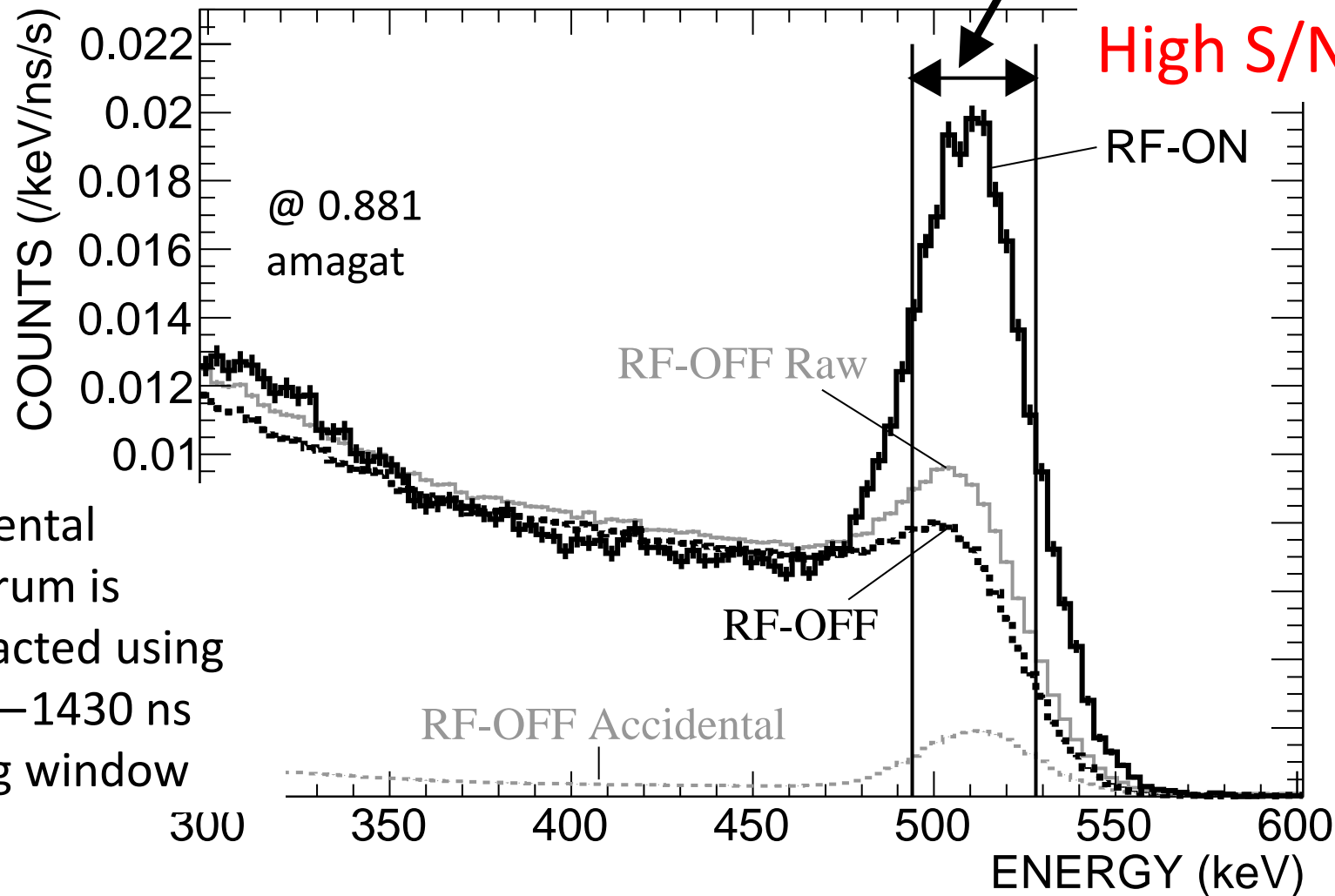

cf. S/N of previous experiment

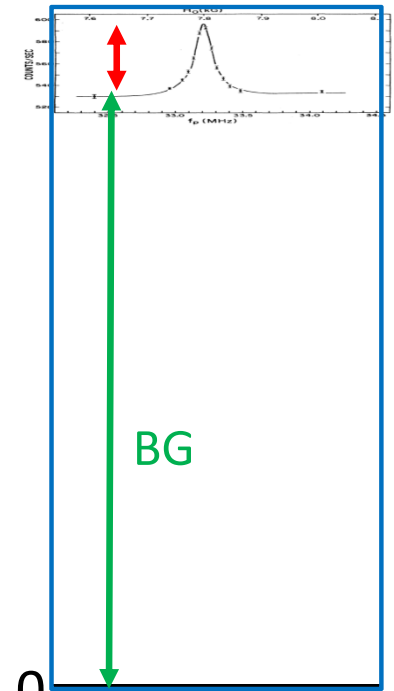

Accidental spectrum is subtracted using 1000–1430 ns timing window

2γ decay rate increases because of the Zeeman transition. Calculate $(\text{RF-ON} - \text{RF-OFF}) / \text{RF-OFF}$ of count rates in the 511 keV $\pm 1\sigma$ energy window.

Resonance line

- Scanned by Magnetic Field with the fixed RF frequency and power.
- 50—440 ns is divided to 11 sub timing windows.
- Simultaneous fit of all of the gas density, magnetic field strength, and (sub) timing windows.
- Time evolution of Δ_{HFS} and pick-off rate ($\propto nv^{3/5}$) is taken into account.

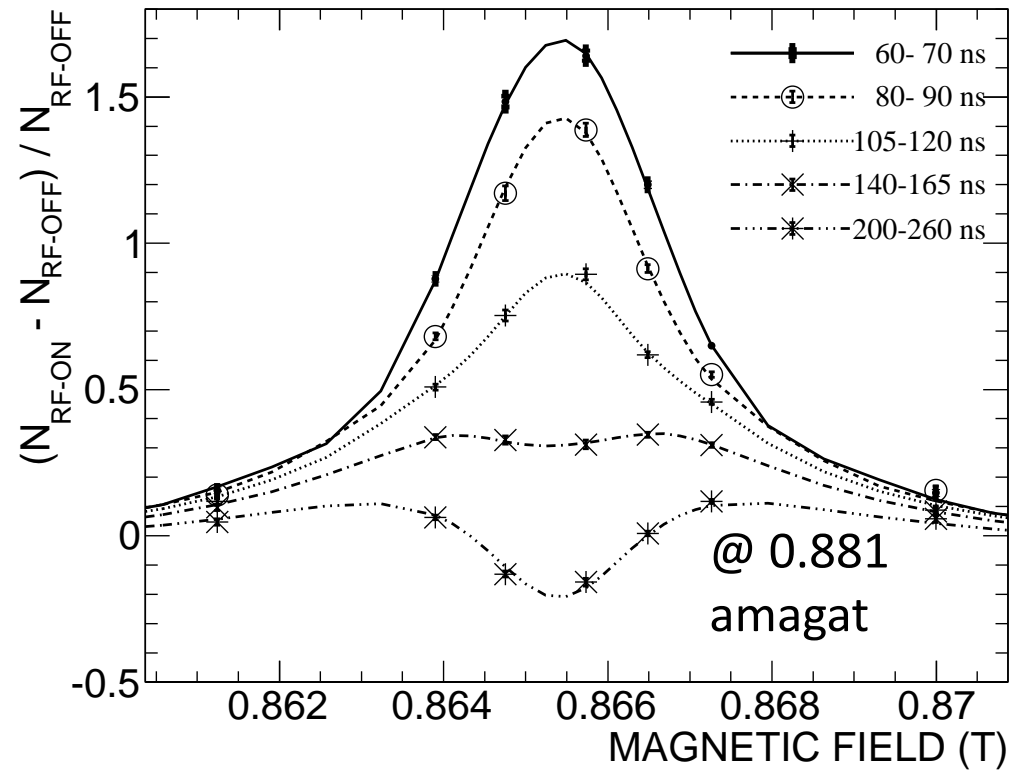
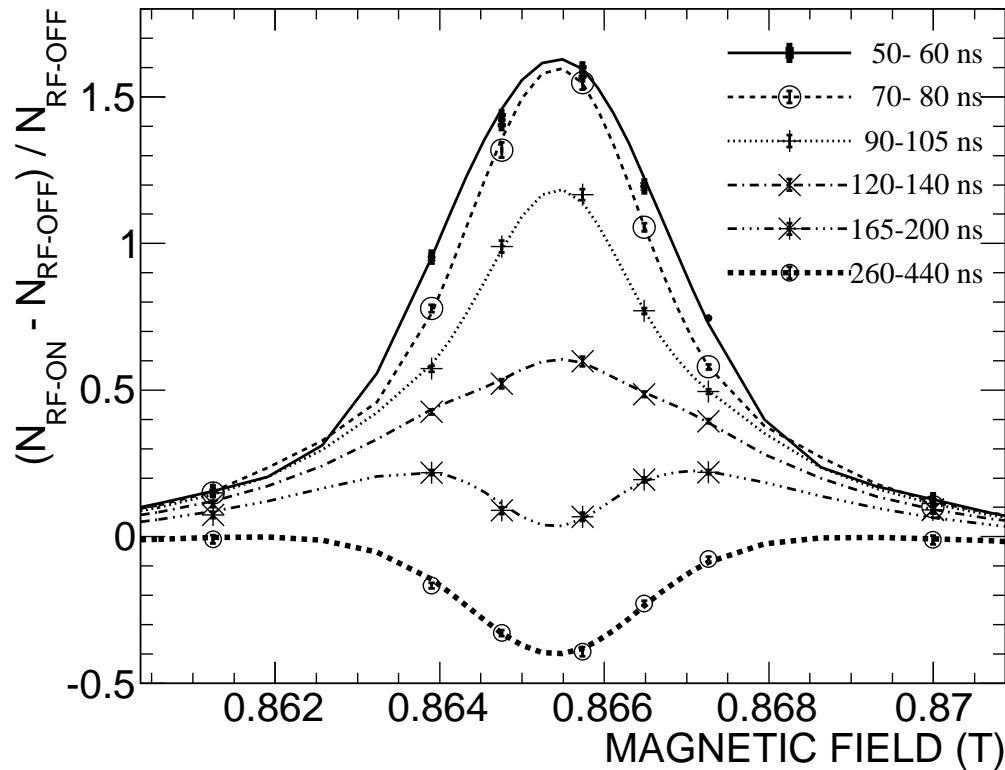

$$\Delta_{\text{HFS}} = 203.394 \ 2(16) \text{ GHz (8.0 ppm)} \quad \chi^2/\text{ndf} = 633.3 / 592 \quad (p = 0.12)$$

Quality check: gas-density dependence of Ps-HFS

Completely separate analysis which determine Δ_{HFS} value at each gas density has been performed to provide additional insight into the complete experimental data set and confirm their quality, although **this method cannot take into account the time evolution of Ps-HFS.**

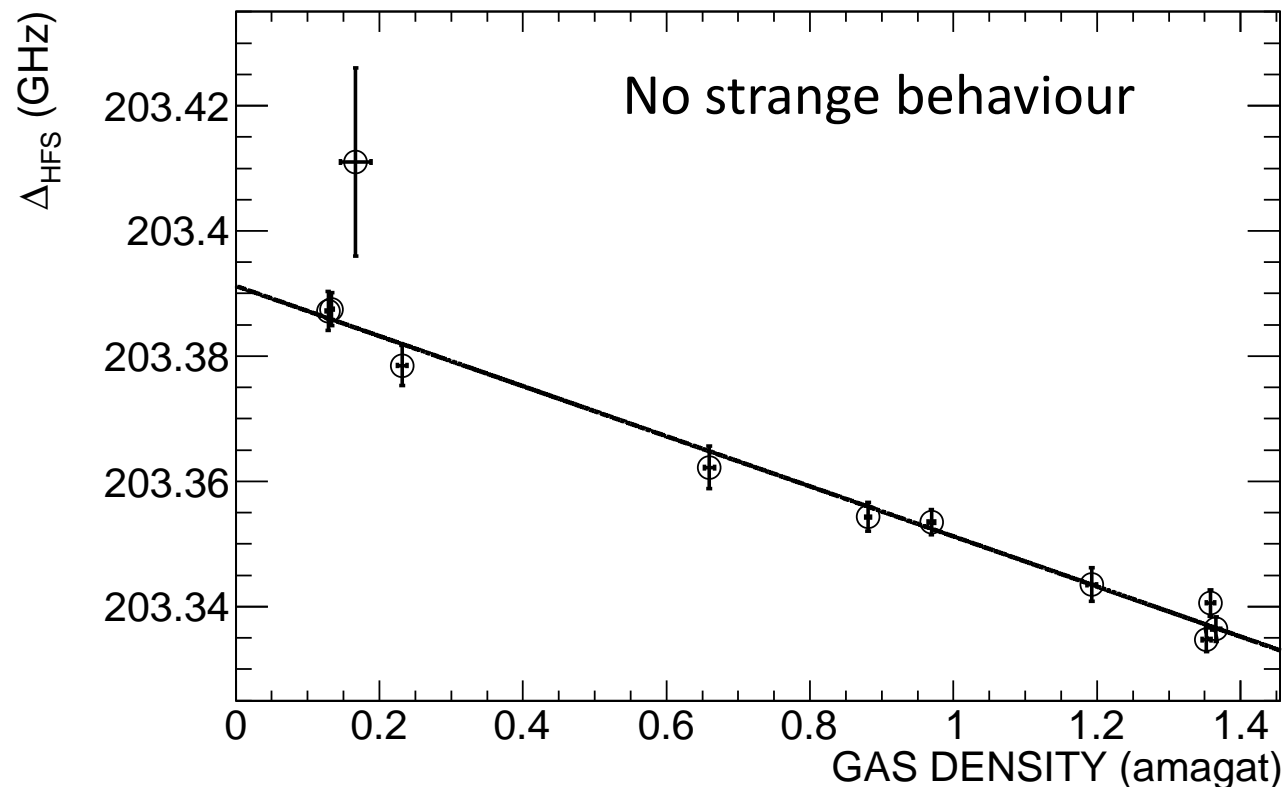

Systematic errors (Main ones)

	Source	ppm in Δ_{HFS}
<i>Material Effect</i>	o-Ps pick-off rate	3.5
	Gas density measurement	1.0
	Spatial distribution of density and temperature of gas in the RF cavity	2.5
	Thermalization of Ps	1.9
<i>Magnetic Field</i>	Non-uniformity	3.0
	Offset and reproducibility	1.0
	NMR measurement	1.0
<i>RF</i>	RF power	1.2
	Q_L value of RF cavity	1.2
	RF frequency	1.0
<i>Analysis</i>	Choice of timing window	1.8
	Quadrature sum	6.4

Combined with 8.0 ppm stat. err., $\Delta_{\text{HFS}} = 203.394\ 2(21)$ GHz (10 ppm).

Estimation of non-thermalized o-Ps effect

- In order to evaluate the non-thermalized o-Ps effect on Ps-HFS, fitting without taking into account the time evolution of Δ_{HFS} and pick-off rate was performed. (well-thermalized assumption)
- Other procedures were the same (used 50 – 440 ns timing window)
- Result was:
203.392 2(16) GHz ($\chi^2/\text{ndf}=721.1/592$, $p=2\times 10^{-4}$)
(*cf.* with time evolution 203.394 2(16) GHz, ($\chi^2/\text{ndf}=633.3/592$, $p=0.12$))
- This value is lower than the fit with time evolution by **as large as 10 ± 2 ppm**. This is comparable to the discrepancy of previous experimental results and theory (16 ppm).
- This effect might be larger if no timing window is applied, since Ps-HFS is dramatically changing in the timing window of 0—50 ns because of the rapid change of Ps velocity.
- It strongly suggests that the reason of the discrepancy in Δ_{HFS} is the effect of non-thermalized Ps.

Result

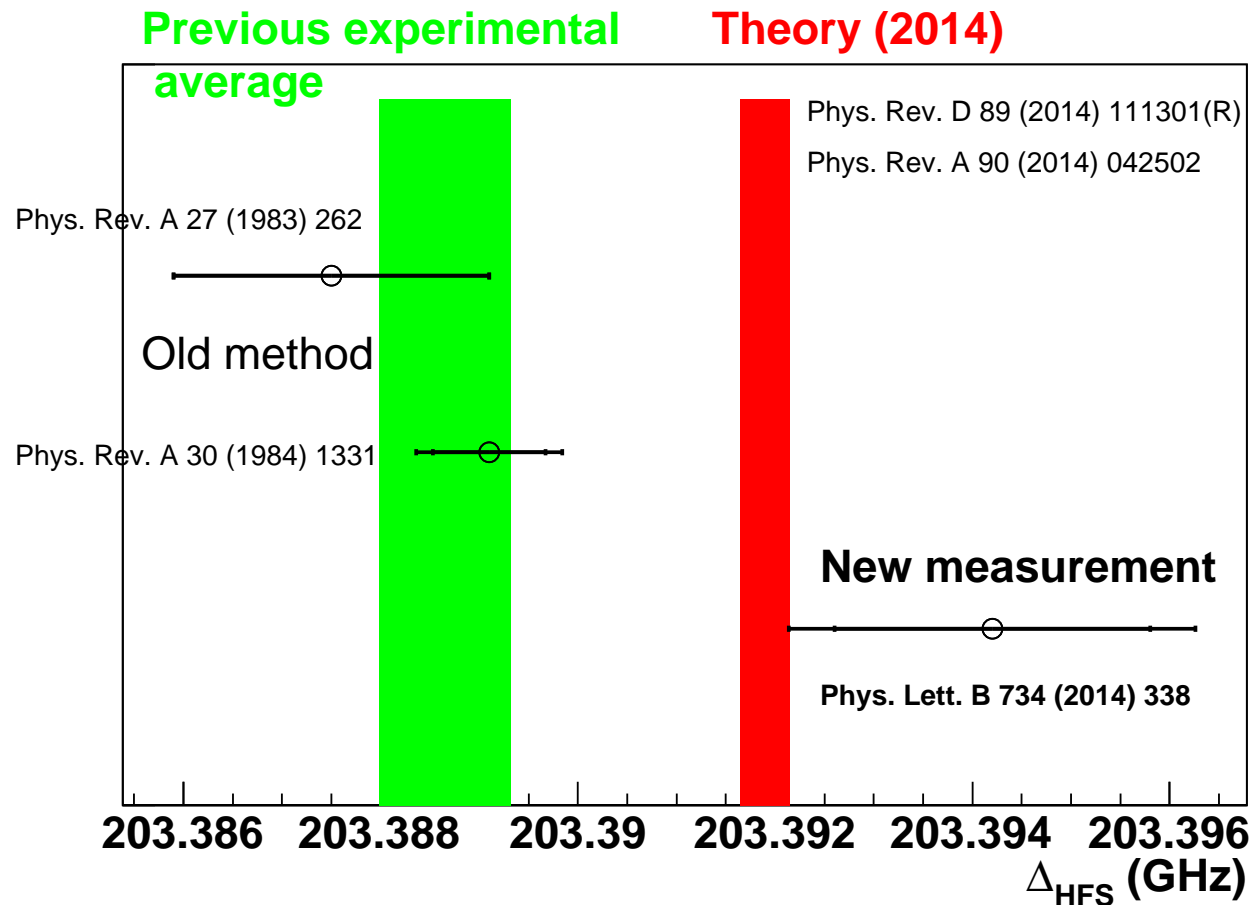

Favors QED calculation

(Consistent with theory within **1.1 σ** , disfavors previous experiments by **2.6 σ**)

Our new result taking into account the Ps thermalization is:

$$\Delta_{\text{HFS}} = 203.394\,2 \pm 0.001\,6 \text{ (stat., 8.0 ppm)} \\ \pm 0.001\,3 \text{ (sys., 6.4 ppm) GHz}$$

Future prospects

Measurement in vacuum using slow positron beam

(hopefully better than 1 ppm result within 4—5 years)

- High statistics (scan in vacuum instead of extrapolation)
- Completely free from material effect
- Short measurement period reduces systematic errors

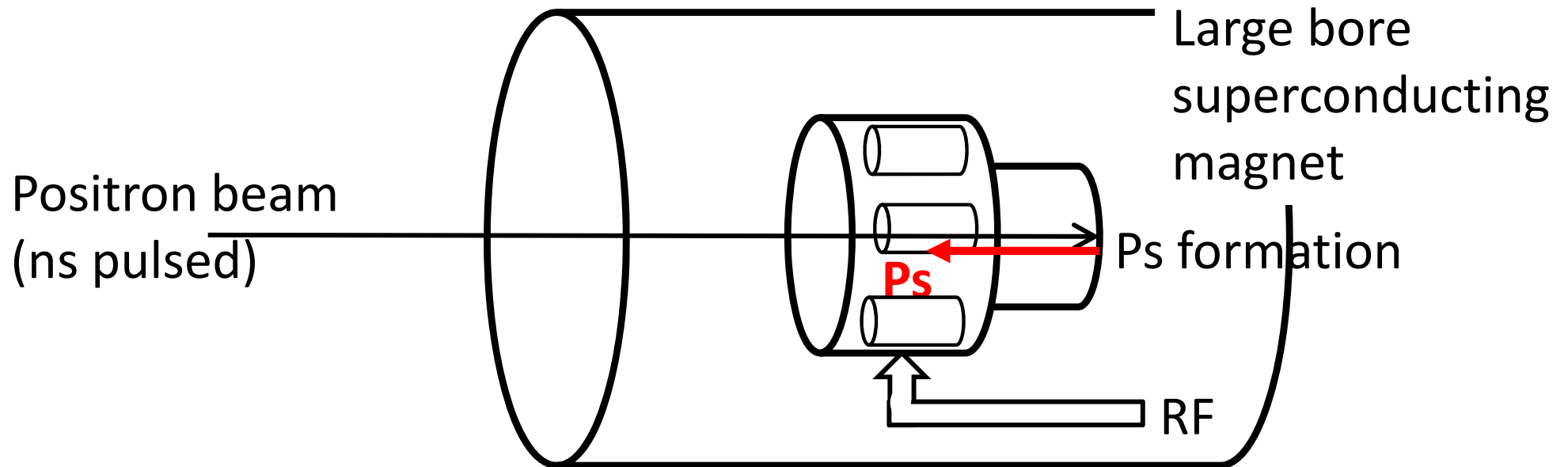

Conclusion

There is a large 4.5σ discrepancy of Ps-HFS between the previous experimental values and theoretical calculation. We performed a new precise measurement which obtains time information.

- It reduced possible systematic uncertainties in the previous experiments (Non-thermalized Ps effect and Non-uniformity of magnetic field).
- Ps thermalization function was measured to treat material effect correctly. Time evolution of Δ_{HFS} and pick-off rate due to Ps thermalization was taken into account.
- **Non-thermalized Ps effect turned out to be as large as 10 ± 2 ppm.** The result taking into account the Ps thermalization effect correctly was $\Delta_{\text{HFS}} = 203.394\ 2 \pm 0.001\ 6$ (stat., 8 ppm) $\pm 0.001\ 3$ (syst., 6.4 ppm) GHz, which **is consistent with QED calculation within 1.1σ** , whereas it disfavors the previous measurements by 2.6σ .
- **Our new result shows that the Ps thermalization effect is crucial for the measurement.**

Backup

How to measure the Ps velocity $v(t)$?

- Use pick-off of o-Ps
- $\text{pick-off}(t)$
 = pick-off cross section
 x density of material
 x o-Ps amount (t)
 x $v(t)^{0.6}$

$$v(t)^{0.6} \propto \frac{\text{pick-off (} 2\gamma \text{ decay)}}{\text{o-Ps (} 3\gamma \text{ decay)}}$$

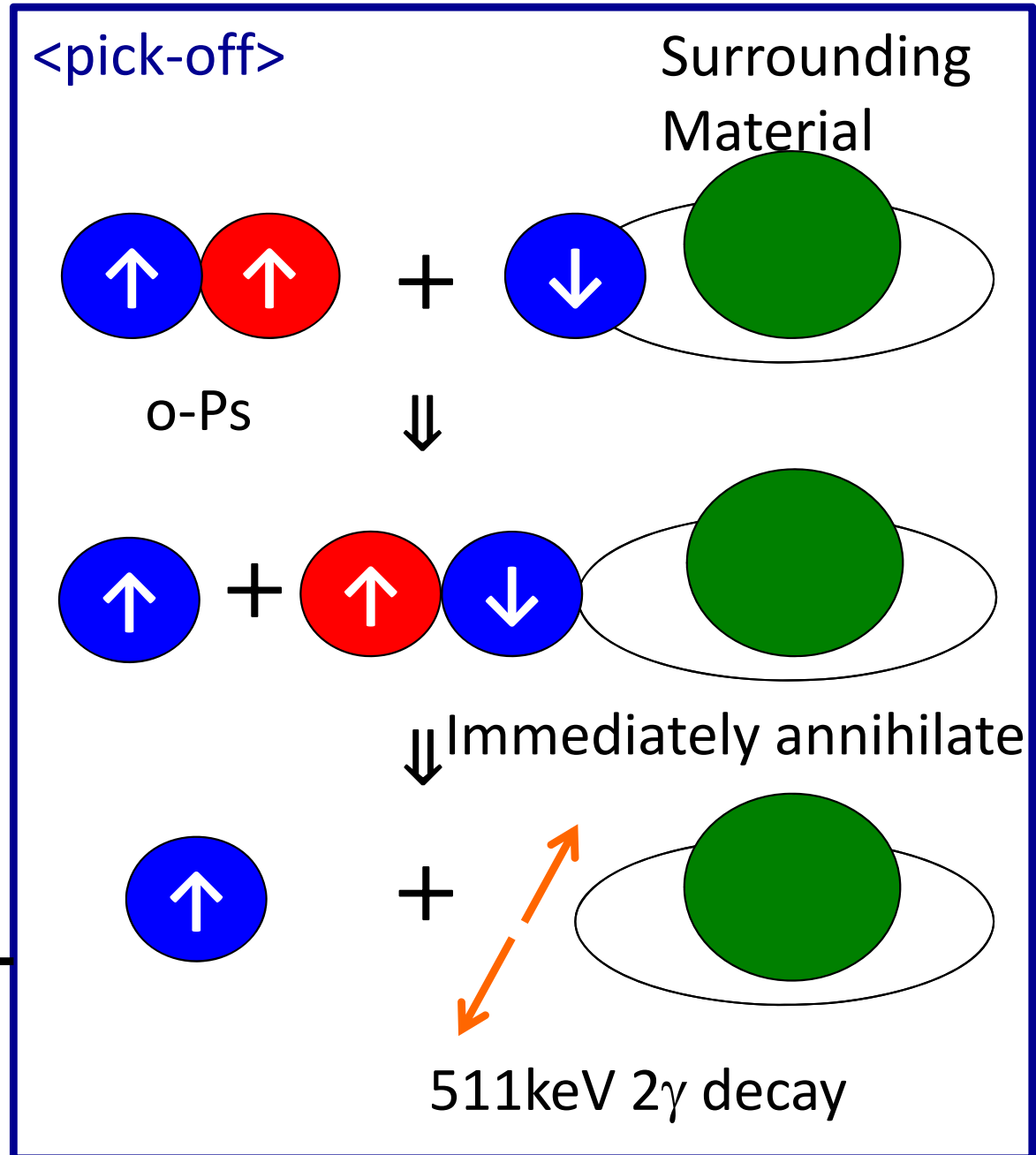

Measurement of Ps Thermalization Experimental Setup (Overall)

- Timing; START by Plastic Scintillator & STOP by Ge detector
- Stop e^+ in the gas and form Ps
- Source is inside the vacuum chamber.
- Change thermalization condition by changing the gas pressures.

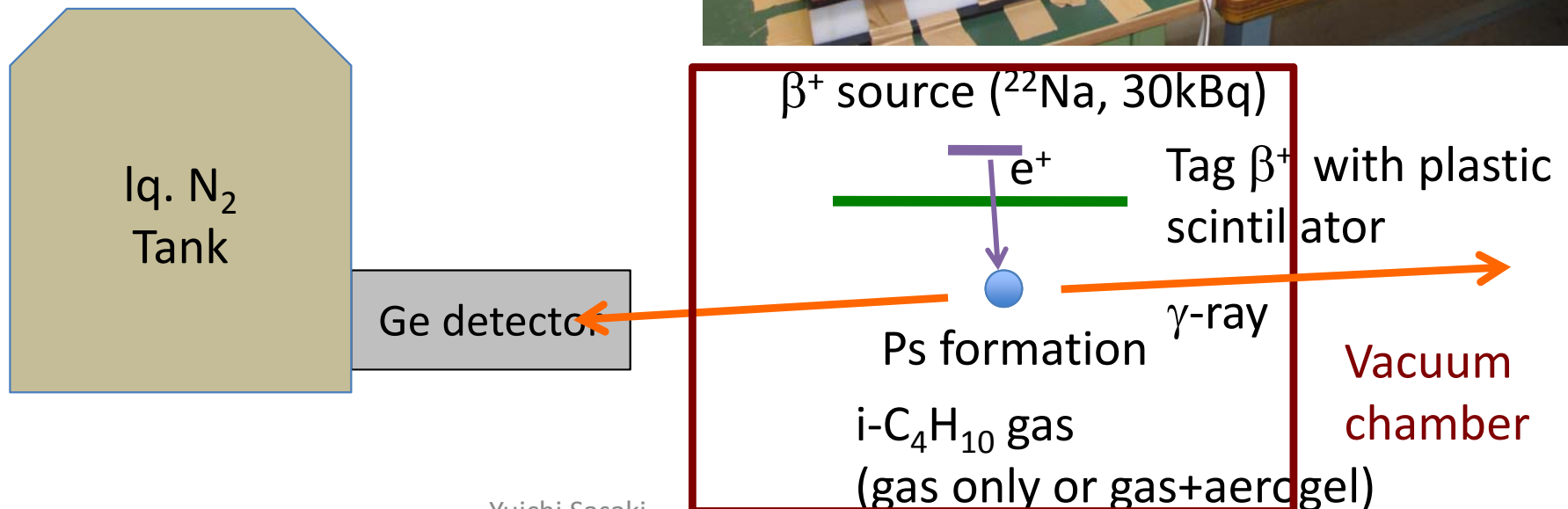
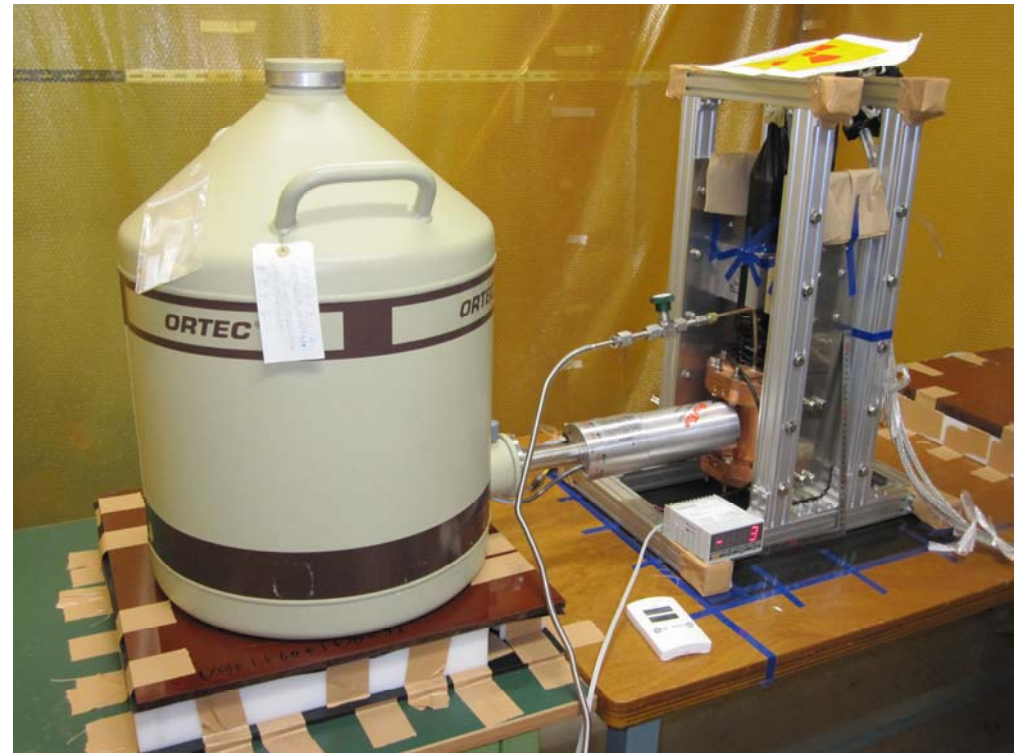

Estimate amounts of o-Ps and pick-off

- 1, Make energy spectrum at each timing window
- 2, o-Ps is normalized at continuous region (480—500 keV).
- 3, 511 ± 3 keV is taken as pick-off
- 4, Efficiencies of o-Ps, pickoff, and pileup are estimated by MC simulation.

Isobutane only / Isobutane + aerogel measurement.
Change gas pressure, measure 2g/3g at various gas pressures

$$v(t)^{0.6} \propto \frac{\text{pick-off (2}\gamma \text{ decay)}}{\text{o-Ps (3}\gamma \text{ decay)}}$$

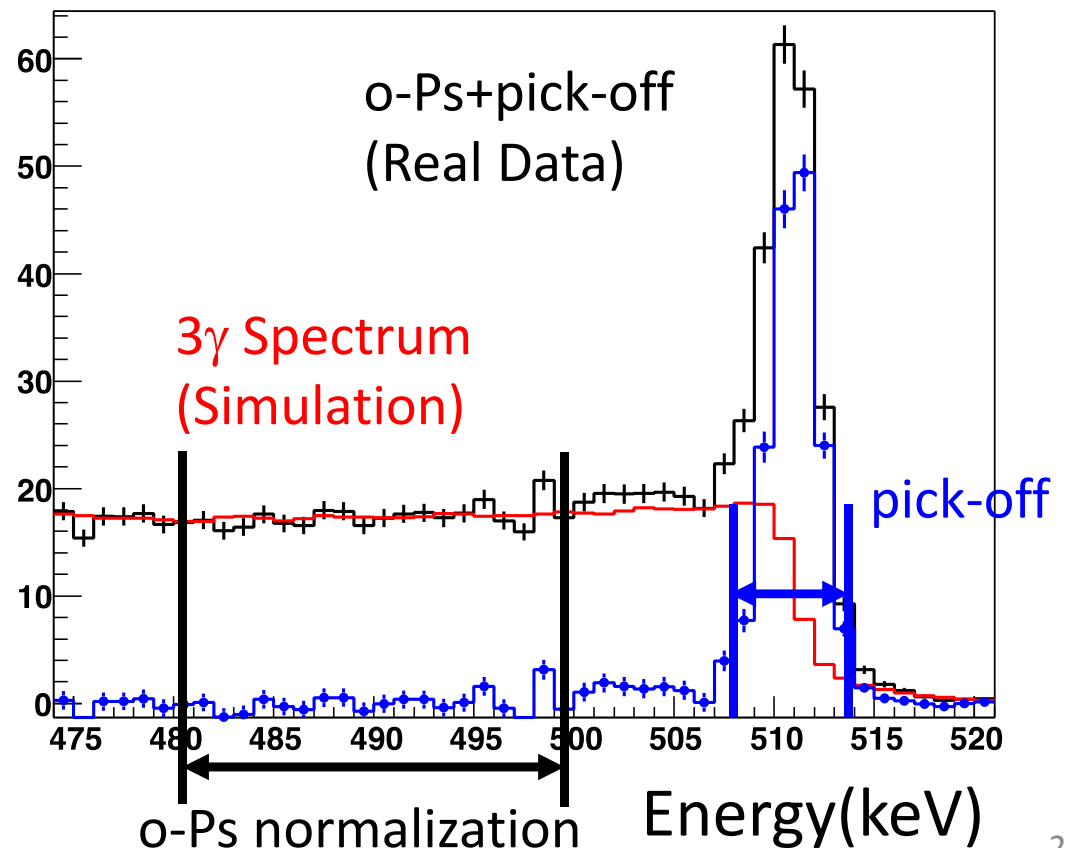

Analysis of thermalization measurement

- Use timing window of 40—800 ns in order to avoid prompt peak. Use the following equation for fitting.

Parameter to fit: σ_m : Momentum-transfer cross section

$$\frac{d}{dt} E_{av}(t) = -\sqrt{2m_{Ps}E_{av}(t)} \left(E_{av}(t) - \frac{3}{2}k_B T \right) \left(\frac{8}{3} \sqrt{\frac{2}{3\pi}} \frac{2\sigma_m n}{M} + \alpha \left(\frac{E_{av}(t)}{k_B T} \right)^\beta \right)$$

Aerogel term

m_{Ps} : Ps mass
 n : gas density
 M : mass of molecule

from J. Phys. B **31** (1998) 329 Y. Nagashima, et al.

- Thermalization of Ps before 40 ns, where kinetic energy of Ps is high, has been already measured by Doppler Broadening Spectroscopy (DBS) method to be $\sigma_m = 146 \pm 11 \text{ \AA}^2$, $E_0 = 3.1^{+1.0}_{-0.7}$ eV (initial kinetic energy) DBS: Phys. Rev. A **67**, 022504 (2003)
- Isobutane has a rovibrational level at 0.17 eV. Value of σ_m can be different above (DBS) and below (pick-off) this level. → Fit with fixed initial condition of DBS result, but change σ_m at 0.17 eV.

2 γ /3 γ fitting

Velocity dependence of pickoff rate in isobutane gas

$$\propto v^{0.6} (= E^{0.3})$$

Simultaneous fit of all gas densities

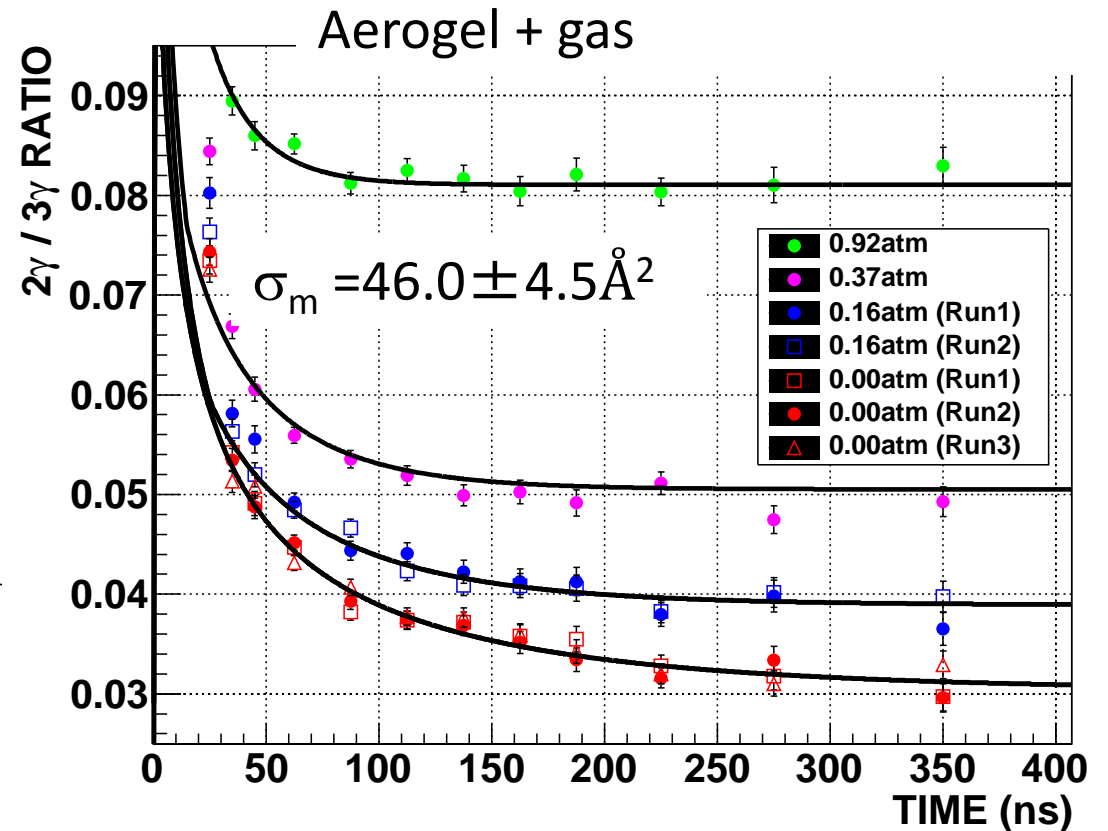
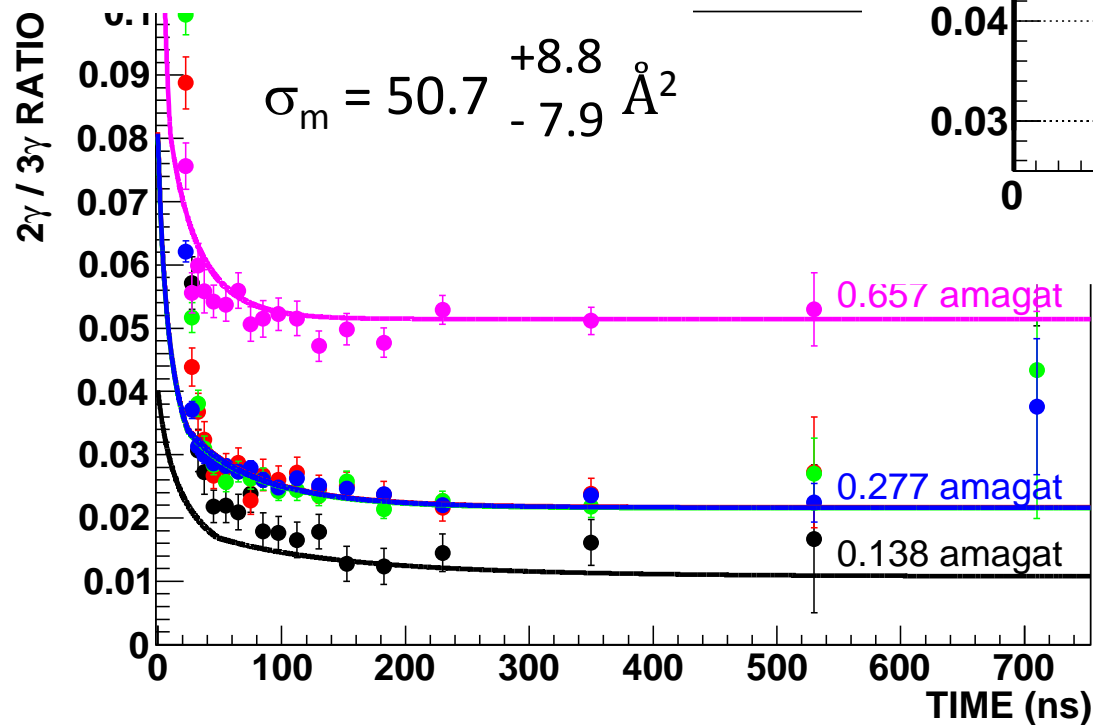

Consistent results from gas-only measurement and with aerogel measurement.
 mean $\sigma_m = 47.2 \pm 3.9 \text{ \AA}^2$
 systematic error 5.4 \AA
 $\rightarrow \sigma_m = 47.2 \pm 6.7 \text{ \AA}^2$